

全新五十鈴環保6型 30噸車陣

		CYH52手波型號	
型號 Model	CYH52SD-7S-VI	CYH52TX-7S-VI	
廢氣排放標準 Emission Standard	環保六型 Euro VI		
總重量(公斤) G.V.W. (kg)	30,000		
乘客量 (連司機) Seating Capacity	1 + 2 座位		
車身尺寸 Dimensions			
全長(毫米) Overall Length (mm)	8,840	10,665	
全闊(毫米) Overall Width (mm)	2,490		2,490
全高(毫米) Overall Height (mm)	3,015		2,985
輪距(毫米) Wheelbase (mm)	5,650		5,980
引擎 Engine			
型號 Model	6WG1E6N		
類別 Type	直列式六氣缸，24氣閥，可變活瓣渦輪增壓 (VGS Turbo)連中置冷卻器， 廢氣再循環裝置 (EGR)，電子控制高壓共軌噴注系統 (CRS) 柴油微粒過濾器+選擇性催化還原 (DPD+SCR) In-line, 6 Cylinders, 24 Valves, Variable Geometry System Turbocharger (VGS Turbo) with Intercooler Exhaust Gas Recirculation (EGR), Common Rail System (CRS), Diesel Particulate Diffuser (DPD) + Selective Catalytic Reduction (SCR)		
汽缸容積(毫升) Displacement (cc)	15,681		
最大馬力(匹/轉) Max. Output (PS/rpm)	420 / 1,800		
最大扭力(公斤-米/轉) Max. Torque (kgm/rpm)	190 / 1,300		
油缸容積(公升) Fuel Tank Capacity (litre)	300	400	
尿素缸容積(公升) Adblue Tank Capacity (litre)	28		
波箱 Transmission			
型號 Model	MJT7S 7前1後 手動波箱 7 Forward 1 Reverse, Manual		
波段比 Gear Ratios	1 ~ 7波 : 6.833 ~ 0.728		
最終傳動比 Final Gear Ratio	5.125	4.875	
離合器 Clutch			
類別 Type	單乾板式附避震彈簧，空氣輔助液壓控制 Dry Single Plate with Cushioning Spring, Hydraulic Control with Air Assisted		
轉向系統 Steering			
類型 Type	走珠式動力輔助轉向系統 Recirculating Ball with Power Assisted		
懸掛系統 Suspension			
前懸掛 Front	半橢圓鋼合金多層葉片式彈簧，雙重液壓吸震筒 Semi-elliptical, Alloy Steel Leaf Spring, Double Acting Telescopic Shock Absorber	龍船葉片式彈簧，雙重液壓吸震筒 Taper Leaf Spring, Double Acting Telescopic Shock Absorber	
後懸掛 Rear	半橢圓鋼合金多層葉片式彈簧 Semi-elliptical, Alloy Steel Leaf Spring		龍船葉片式彈簧 Taper Leaf Spring
前軸 Front Axle	倒置愛里奧工字架 Reverse Elliot "I" Beam		
廠方設計負重(公斤) Design Axle Loading (kg)	7,500 + 7,500		
運輸署批核負重(公斤) Allocated Weight (kg)	7,100 + 7,100		
後軸 Rear Axle	琵琶全浮內擺線齒輪 Banjo, Full Floating Type, Hypoid Gear		
廠方設計負重(公斤) Design Axle Loading (kg)	10,500 + 10,500		
運輸署批核負重(公斤) Allocated Weight (kg)	9,000 + 9,000		
制動系統 Brake			
制動操作 Service	前後鼓刹，全風雙管路楔式制動，虛位自動調節器，ABS防鎖刹車系統 Front&Rear Drum, Full Air, Dual Circuit, Wedge Type, Brake Auto Adjuster, Anti-lock Brake System (ABS)		
停車手制 Parking	後輪彈簧制動器 Spring Brake Actuators Acting on Rear Wheels		
輔助制動 Auxiliary	廢氣刹車，斜坡起動輔助系統(HSA) Exhaust Brake, Hill-Start-Aid (HSA)		
車陣 Frame			
類型 Type	梯型車陣 Ladder Type		
陣闊(毫米) Width (mm)	850		
輪胎及車輪 Tire & Wheel			
車胎 Tire	295/80R22.5 無內膽原子胎	295/80R22.5 Tubeless Radial Tire	
車輪 Wheel	22.5 x 8.25 (10 螺絲)		22.5 x 8.25 (10 Studs)
標準裝備 Standard Equipment			
	原廠冷氣，電腦錶板多功能顯示器(MID) AM/FM收音連CD機，駕駛席SRS安全氣囊 電動揭屋仔，氣墊避震駕駛室，氣墊座椅(駕駛座) 電動車窗，車門轉向輔助燈，中央門鎖 電動摺鏡臂(乘客座)，發熱線倒後鏡 Factory Built Air Conditioner, Multi-Information Display (MID) AM/FM CD Player, SRS Airbag on Driver Side Electrical Driven Tilt Cab, Cushioning Cab,Air Suspension Driver's Seat, Power Windows, Door Mount Cornering Lamps, Central Door Lock Electronic Retractable Side Mirror (Passenger Side), Heated Side Mirrors		

以上規格只供參考。如有更改，恕不另行通告。

062018

CYH52SD-7S-VI

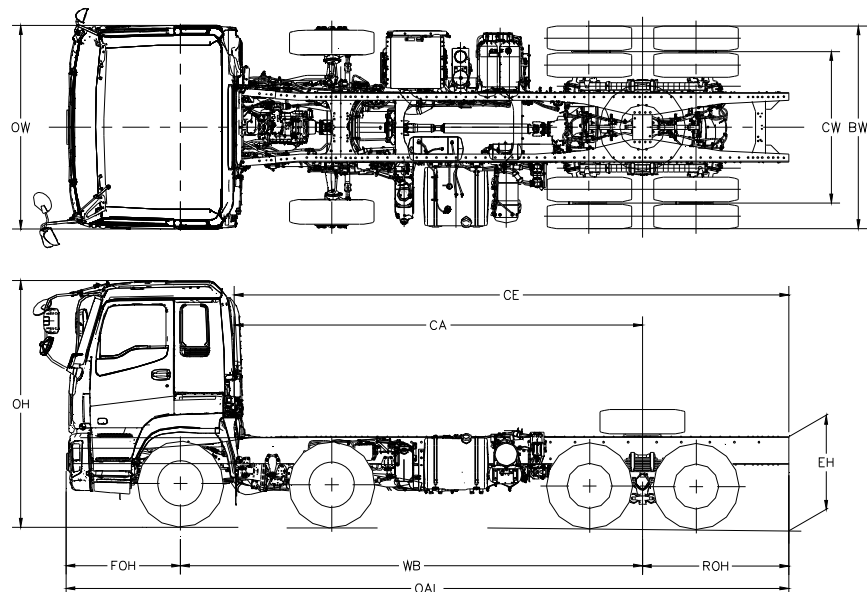

型號 (Model)	OAL	WB	FOH	ROH	CE	CA	OW	AW	BW	CW	OH Approx	EH Approx	
CYH52SD-7S-VI	8840	5650	1400	1790	6784	4994	2490	2065	2480	1850	3020	1130	毫米 (mm)
	348	222	55	70	259	190	98	81	97	72	118	44	寸 (in)

CYH52TX-7S-VI

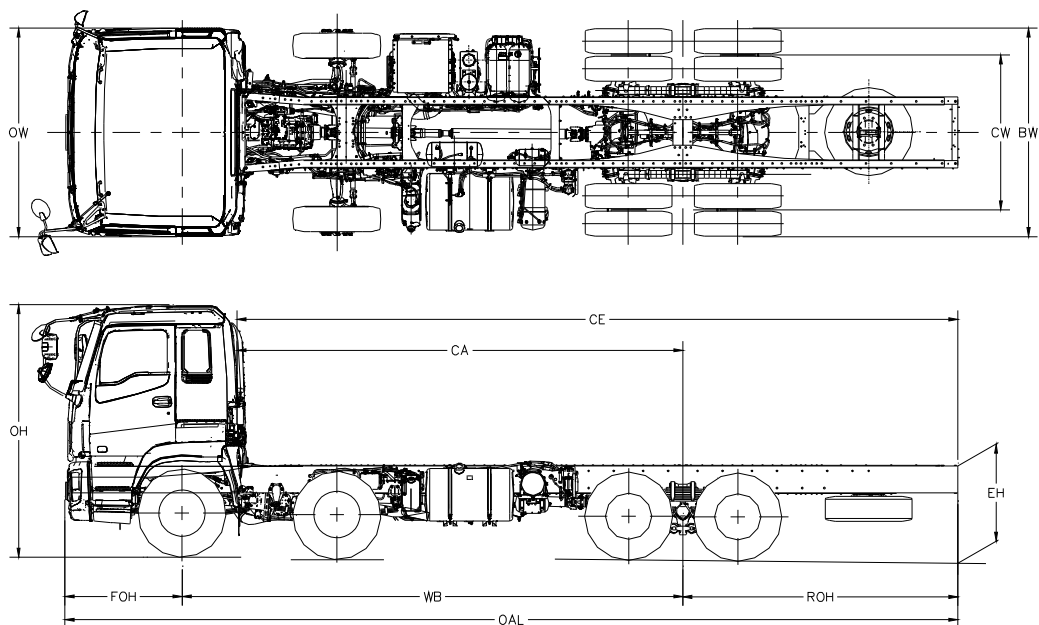

型號 (Model)	OAL	WB	FOH	ROH	CE	CA	OW	AW	BW	CW	OH Approx	EH Approx	
CYH52TX-7S-VI	10665	5980	1400	3285	8609	5324	2490	2065	2480	1850	2985	1130	毫米 (mm)
	420	235	55	129	331	202	98	81	97	72	117	44	寸 (in)

以上尺寸只供參考。如有更改，恕不另行通告。