

全新五十鈴環保6型 38噸拖頭

	EXR52 手波型號
型號 Model	EXR52E-7S-VI-C
廢氣排放標準 Emission Standard	環保六型 Euro VI
總拖量(公斤) G.C.W. (kg)	38,000
乘客量 (連司機) Seating Capacity	1 + 2 座位
車身尺寸 Dimensions	
全長 (毫米) Overall Length (mm)	5,820
全闊 (毫米) Overall Width (mm)	2,490
全高 (毫米) Overall Height (mm)	2,960
輪距 (毫米) Wheelbase (mm)	3,450
引擎 Engine	
型號 Model	6WG1E6N
類別 Type	直列式六氣缸，24氣閥，可變活瓣渦輪增壓 (VGS Turbo)連中置冷卻器， 廢氣再循環裝置 (EGR)，電子控制高壓共軌噴注系統 (CRS) 柴油微粒過濾器+選擇性催化還原 (DPD+SCR) In-line, 6 Cylinders, 24 Valves, Variable Geometry System Turbocharger (VGS Turbo) with Intercooler Exhaust Gas Recirculation (EGR), Common Rail System (CRS), Diesel Particulate Diffuser (DPD) + Selective Catalytic Reduction (SCR)
汽缸容積 (毫升) Displacement (cc)	15,681
最大馬力 (匹/轉) Max. Output (PS/rpm)	420 / 1,800
最大扭力 (公斤-米/轉) Max. Torque (kgm/rpm)	190 / 1,300
油缸容積 (公升) Fuel Tank Capacity (litre)	400
尿素缸容積 (公升) Adblue Tank Capacity (litre)	28
波箱 Transmission	
型號 Model	MJT7S 7前1後 手動波箱 7 Forward 1 Reverse, Manual
波段比 Gear Ratios	1 ~ 7波 : 6.833 ~ 0.728
最終傳動比 Final Gear Ratio	4.333
離合器 Clutch	
類別 Type	雙乾板式附避震彈簧，空氣輔助液壓控制 Dry Twin Plate with Cushioning Spring, Hydraulic Control with Air Assisted
轉向系統 Steering	
類型 Type	走珠式動力輔助轉向系統 Recirculating Ball with Power Assisted
懸掛系統 Suspension	
前懸掛 Front	龍船葉片式彈簧，雙重液壓吸震筒 Taper Leaf Spring, Double Acting Telescopic Shock Absorber
後懸掛 Rear	半橢圓鋼合金多層葉片式彈簧 Semi-elliptical, Alloy Steel Leaf Spring
前軸 Front Axle	倒置愛里奧工字架 Reverse Elliot "I" Beam
廠方設計負重 (公斤) Design Axle Loading (kg)	7,500
運輸署批核負重 (公斤) Allocated Weight (kg)	7,100
後軸 Rear Axle	琵琶全浮內擺線齒輪 Banjo, Full Floating Type, Hypoid Gear
廠方設計負重 (公斤) Design Axle Loading (kg)	13,000
運輸署批核負重 (公斤) Allocated Weight (kg)	10,000
制動系統 Brake	
制動操作 Service	前後鼓刹，全風雙管路楔式制動，虛位自動調節器，ABS防鎖死車系統 Front&Rear Drum, Full Air, Dual Circuit, Wedge Type, Brake Auto Adjuster, Anti-lock Brake System (ABS)
停車手制 Parking	前後輪彈簧制動器 Spring Brake Actuators Acting on Front&Rear Wheels
輔助制動 Auxiliary	廢氣制車 Exhaust Brake
磨盤 Coupling	
型號 Model	JOST JSK37C
設計負重 (公斤) Design Loading (kg)	20,000
輪胎及車輪 Tire&Wheel	
車胎 Tire	295/80R22.5 無內膽原子胎 295/80R22.5 Tubeless Radial Tire
車輪 Wheel	22.5 x 8.25 (10 螺絲) 22.5 x 8.25 (10 Studs)
標準裝備 Standard Equipment	
	原廠冷氣，電腦錶板多功能顯示器(MID) AM/FM收音連CD機，駕駛席SRS安全氣囊 電動揭屋仔，氣墊避震駕駛室，氣墊座椅(駕駛座) 電動車窗，車門轉向輔助燈，中央門鎖 電動摺鏡臂(乘客座)，發熱線倒後鏡 Factory Built Air Conditioner, Multi-Information Display (MID) AM/FM CD Player, SRS Airbag on Driver Side Electrical Driven Tilt Cab, Cushioning Cab, Air Suspension Driver's Seat, Power Windows, Door Mount Cornering Lamps, Central Door Lock Electronic Retractable Side Mirror (Passenger Side), Heated Side Mirrors

以上規格只供參考。如有更改，恕不另行通告。

062019

EXR52E-7S-VI-C

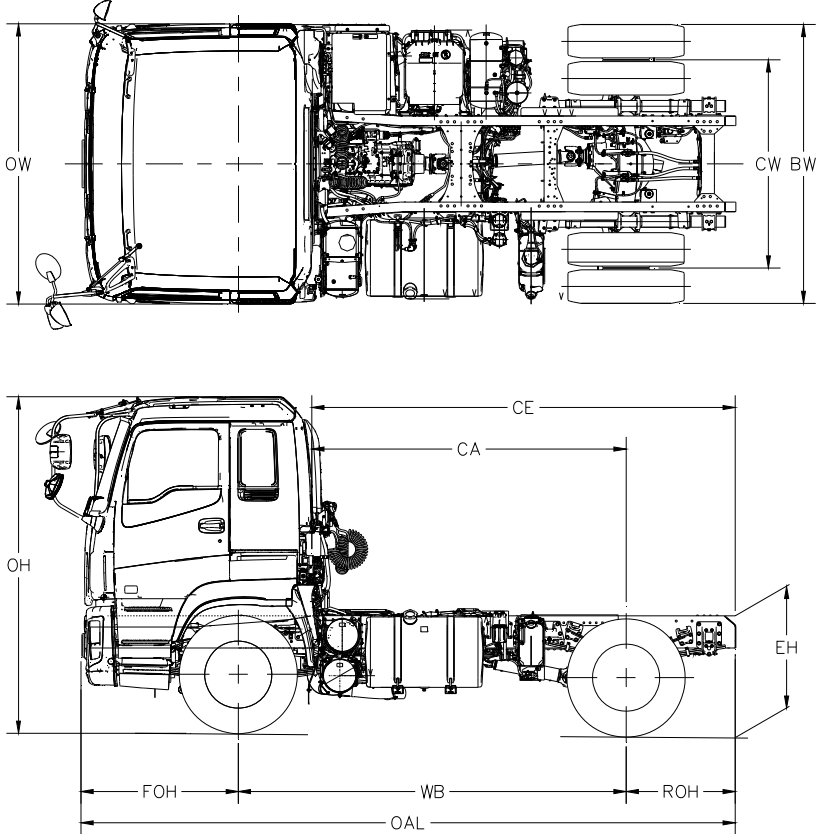

型號 (Model)	OAL	WB	FOH	ROH	OW	CE	CA	BW	CW	OH Approx	EH Approx	
EXR52E-7S-VI-C	5820	3450	1400	970	2490	3764	2794	2480	1850	2960	1285	毫米 (mm)
	229.1	135.8	55.1	38.2	98.0	148.2	110.0	97.6	72.8	116.5	50.6	寸 (in)

以上尺寸只供參考。如有更改，恕不另行通告。