

## 全新五十鈴環保6型 11噸車陣

| 型號 Model                               | FRR90 手波型號  |           | FRR90 Smoother-F 電子自動波型號   |            |
|--|---|-----------|--|------------|
|  | FRR90K-VI   | FRR90M-VI | FRR90KF-VI   | FRR90MF-VI |
| 廢氣排放標準 Emission Standard               | 環保六型 Euro VI  |           |  |            |
| 總重量(公斤) G.V.W. (kg)                    | 11,000  |           |  |            |
| 乘客量 (連司機) Seating Capacity             | 1 + 2 座位 (DAY CAB)  |           |  |            |
| <b>車身尺寸 Dimensions</b>                 |   |           |  |            |
| 全長(毫米) Overall Length (mm)             | 6,975   | 7,875     | 6,975  | 7,875      |
| 全闊(毫米) Overall Width (mm)              | 2,200   | 2,200     | 2,200  | 2,200      |
| 全高(毫米) Overall Height (mm)             | 2,530   | 2,530     | 2,530  | 2,530      |
| 輪距(毫米) Wheelbase (mm)                  | 4,060   | 4,660     | 4,060  | 4,660      |
| <b>引擎 Engine</b>                       |   |           |  |            |
| 型號 Model                               | 4HK1-E6S  |           |  |            |
| 類別 Type                                | 直列式四氣缸，16氣閥，可變活瓣渦輪增壓 (VGS Turbo)連中置冷卻器，<br>廢氣再循環裝置 (EGR)，電子控制高壓共軌噴注系統 (CRS)，<br>柴油微粒過濾器+選擇性催化還原 (DPD+SCR)<br>In-line, 4 Cylinders, 16 Valves, Variable Geometry System Turbocharger (VGS Turbo) with Intercooler<br>Exhaust Gas Recirculation (EGR), Common Rail System (CRS),<br>Diesel Particulate Diffuser (DPD) + Selective Catalytic Reduction (SCR)           |           |  |            |
| 汽缸容積(毫升) Displacement (cc)             | 5,193   |           |  |            |
| 最大馬力(匹/轉) Max. Output (PS/rpm)         | 209 / 2,400   |           |  |            |
| 最大扭力(公斤-米/轉) Max. Torque (kgm/rpm)     | 72 / 1,600  |           |  |            |
| 油缸容積(公升) Fuel Tank Capacity (litre)    | 200   |           |  |            |
| 尿素缸容積(公升) Adblue Tank Capacity (litre) | 16  |           |  |            |
| <b>波箱 Transmission</b>                 |   |           |  |            |
| 型號 Model                               | MZW6P<br>6前1後 手動波箱<br>6 Forward 1 Reverse, Manual   |           | MZW6P 6前1後<br>6前1後 "+/-"式電子自動波箱<br>6 Forward 1 Reverse, Smoother F "+/-" Automatic Shifting Device |            |
| 波段比 Gear Ratios                        | 1 ~ 6波 : 6.615 ~ 0.722  |           |  |            |
| 最終傳動比 Final Gear Ratio                 | 4.875   |           |  |            |
| <b>離合器 Clutch</b>                      |   |           |  |            |
| 類別 Type                                | 單乾板式附避震彈簧，空氣輔助液壓控制<br>Dry Single Plate with Cushioning Spring,<br>Hydraulic Control with Air Assisted   |           | 濕式多板離合器<br>Wet Type Multi Plate  |            |
| <b>轉向系統 Steering</b>                   |   |           |  |            |
| 類型 Type                                | 走珠式動力輔助轉向系統 Recirculating Ball with Power Assisted  |           |  |            |
| <b>懸掛系統 Suspension</b>                 |   |           |  |            |
| 前懸掛 Front                              | 半橢圓鋼合金多層葉片式彈簧，雙重液壓吸震筒，防滾桿<br>Semi-elliptical, Alloy Steel Leaf Spring, Double Acting Telescopic Shock Absorber, Anti-roll Bar   |           |  |            |
| 後懸掛 Rear                               | 半橢圓鋼合金多層葉片式彈簧 Semi-elliptical, Alloy Steel Leaf Spring  |           |  |            |
| 前軸 Front Axle                          | 倒置愛里奧工字架 Reverse Elliot "I" Beam  |           |  |            |
| 廠方設計負重(公斤) Design Axle Loading (kg)    | 3,600   |           |  |            |
| 運輸署批核負重(公斤) Allocated Weight (kg)      | 3,600   |           |  |            |
| 後軸 Rear Axle                           | 琵琶型全浮式 Banjo, Full Floating Type  |           |  |            |
| 廠方設計負重(公斤) Design Axle Loading (kg)    | 7,700   |           |  |            |
| 運輸署批核負重(公斤) Allocated Weight (kg)      | 7,600   |           |  |            |
| <b>制動系統 Brake</b>                      |   |           |  |            |
| 制動操作 Service                           | 前後鼓刹，氣動輔助液壓式制動，虛位自動調節器，ABS防鎖刹車系統<br>Front&Rear Drum, Air Over Hydraulic, Brake Auto Adjuster, Anti-lock Brake System (ABS)  |           |  |            |
| 停車手制 Parking                           | 後輪彈簧制動器 Spring Brake Actuators Acting on Rear Wheels  |           |  |            |
| 輔助制動 Auxiliary                         | 廢氣刹車，斜坡起動輔助系統(HSA)<br>Exhaust Brake, Hill-Start-Aid (HSA)   |           |  |            |
| <b>車陣 Frame</b>                        |   |           |  |            |
| 類型 Type                                | 梯型車陣 Ladder Type  |           |  |            |
| 陣闊(毫米) Width (mm)                      | 840   |           |  |            |
| <b>輪胎及車輪 Tire &amp; Wheel</b>          |   |           |  |            |
| 車胎 Tire                                | 235/75R17.5 無內膽原子胎  |           | 235/75R17.5 Tubeless Radial Tire   |            |
| 車輪 Wheel                               | 17.5 x 6.75 (6 螺絲)  |           | 17.5 x 6.75 (6 Studs)  |            |
| <b>標準裝備 Standard Equipment</b>         |   |           |  |            |
|  | 原廠冷氣，駕駛席SRS安全氣囊<br>AM/FM收音連CD機，車門轉向輔助燈<br>可揭式駕駛室，避震駕駛室，電動車窗，中央門鎖<br>電動調較角度及電動摺鏡臂(乘客座)，發熱線後鏡<br>Factory Built Air Conditioner, SRS Airbag on Driver Side<br>AM/FM CD Player, Door Mount Cornering Lamps<br>Tilttable and Cushioning Cab, Power Windows, Central Door Lock<br>Electronic Adjustable and Retractable Side Mirror (Passenger Side), Heated Side Mirrors |           |  |            |

以上規格只供參考。如有更改，恕不另行通告。

062018

FRR90K-VI / FRR90KF-VI  
FRR90M-VI / FRR90MF-VI

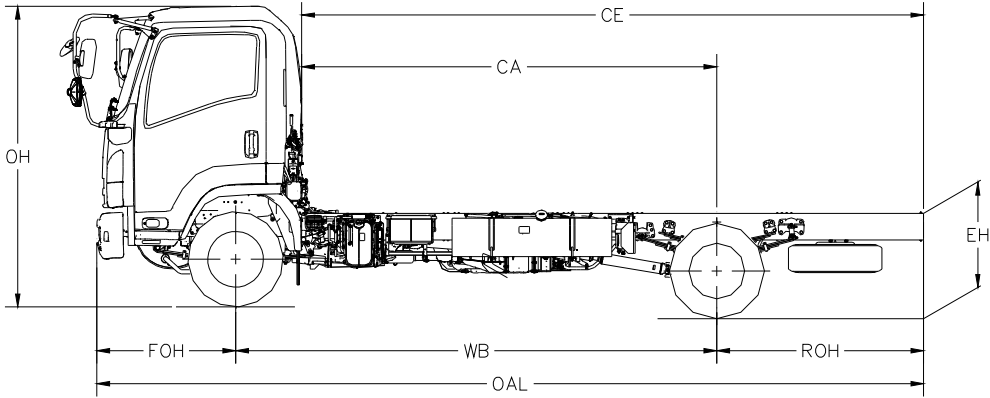
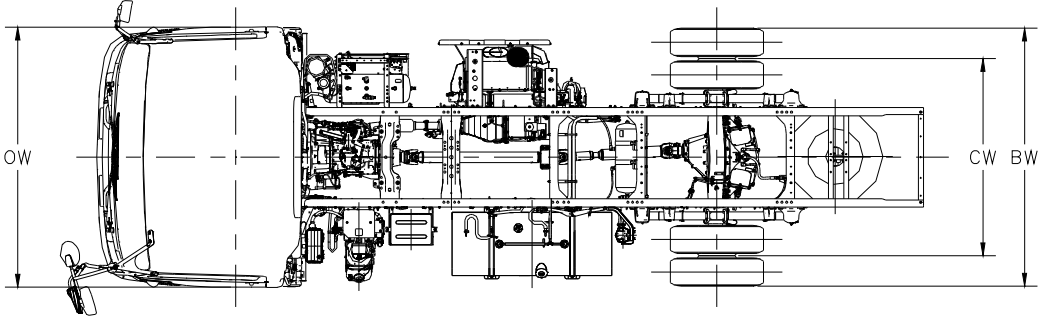

| 型號 (Model)               | OAL           | WB            | FOH          | ROH          | CE            | CA            | OW           | BW           | CW           | OH<br>Approx | EH<br>Approx |                 |
|--------------------------|---------------|---------------|--------------|--------------|---------------|---------------|--------------|--------------|--------------|--------------|--------------|-----------------|
| FRR90K-VI/<br>FRR90KF-VI | 6975<br>274.6 | 4060<br>159.8 | 1170<br>46.1 | 1745<br>68.7 | 5249<br>206.7 | 3504<br>138.0 | 2200<br>86.6 | 2170<br>85.4 | 1660<br>65.4 | 2530<br>99.6 | 940<br>37.0  | 毫米(mm)<br>寸(in) |
| FRR90M-VI/<br>FRR90MF-VI | 7875<br>310   | 4660<br>183   | 1170<br>46   | 2045<br>80   | 6149<br>241   | 4104<br>161   | 2200<br>86   | 2170<br>65   | 1660<br>85   | 2530<br>100  | 940<br>37    | 毫米(mm)<br>寸(in) |

以上尺寸只供參考。如有更改，恕不另行通告。