

全新五十鈴環保6型 14噸車陣

型號 Model	FSR90 手波型號			FSR90 Smoother-F 電子自動波型號		
	FSR90L-VI	FSR90N-VI	FSR90Q-VI	FSR90L-F-VI	FSR90NF-VI	FSR90QF-VI
廢氣排放標準 Emission Standard	環保六型 Euro VI					
總重量(公斤) G.V.W. (kg)	14,000					
乘客量(連司機) Seating Capacity	1 + 2 座位 (FULL CAB)					
車身尺寸 Dimensions						
全長(毫米) Overall Length (mm)	7,255	8,155	9,155	7,255	8,155	9,155
全闊(毫米) Overall Width (mm)	2,260	2,260	2,260	2,260	2,260	2,260
全高(毫米) Overall Height (mm)	2,600	2,600	2,600	2,600	2,600	2,600
輪距(毫米) Wheelbase (mm)	4,360	4,860	5,560	4,360	4,860	5,560
引擎 Engine						
型號 Model	4HK1-E6H					
類別 Type	直列式四氣缸, 16氣閥, 雙段式渦輪增壓(2-Stage Turbo)連中置冷卻器, 廢氣再循環裝置(EGR), 電子控制高壓共軌噴注系統(CRS), 柴油微粒過濾器+選擇性催化還原(DPD+SCR) In-line, 4 Cylinders, 16 Valves, 2-Stage Turbocharger (2-Stage Turbo) with Intercooler Exhaust Gas Recirculation (EGR), Common Rail System (CRS), Diesel Particulate Diffuser (DPD) + Selective Catalytic Reduction (SCR)					
汽缸容積(毫升) Displacement (cc)	5,193					
最大馬力(匹/轉) Max. Output (PS/rpm)	240 / 2,400					
最大扭力(公斤-米/轉) Max. Torque (kgm/rpm)	78 / 1,600					
油缸容積(公升) Fuel Tank Capacity (litre)	200					
尿素缸容積(公升) Adblue Tank Capacity (litre)	16					
波箱 Transmission						
型號 Model	MZW6P 6前1後 手動波箱 6 Forward 1 Reverse, Manual			MZW6P 6前1後 6前1後 "+/-"式電子自動波箱 6 Forward 1 Reverse, Smoother F "+/-" Automatic Shifting Device		
波段比 Gear Ratios	1 ~ 6波 : 6.615 ~ 0.722					
最終傳動比 Final Gear Ratio	5.571					
離合器 Clutch						
類別 Type	單乾板式附避震彈簧, 空氣輔助液壓控制 Dry Single Plate with Cushioning Spring, Hydraulic Control with Air Assisted			濕式多板離合器 Wet Type Multi Plate		
轉向系統 Steering						
類型 Type	走珠式動力輔助轉向系統 Recirculating Ball with Power Assisted					
懸掛系統 Suspension						
前懸掛 Front	半橢圓鋼合金多層葉片式彈簧, 雙重液壓吸震筒, 防滾桿 Semi-elliptical, Alloy Steel Leaf Spring, Double Acting Telescopic Shock Absorber, Anti-roll Bar					
後懸掛 Rear	半橢圓鋼合金多層葉片式彈簧 Semi-elliptical, Alloy Steel Leaf Spring					
前軸 Front Axle	倒置愛里奧工字架 Reverse Elliot "I" Beam					
廠方設計負重(公斤) Design Axle Loading (kg)	5,000					
運輸署批核負重(公斤) Allocated Weight (kg)	5,000					
後軸 Rear Axle	琵琶型全浮式 Banjo, Full Floating Type					
廠方設計負重(公斤) Design Axle Loading (kg)	9,000					
運輸署批核負重(公斤) Allocated Weight (kg)	9,000					
制動系統 Brake						
制動操作 Service	前後鼓刹, 氣動輔助液壓式制動, 虛位自動調節器, ABS防鎖刹車系統 Front&Rear Drum, Air Over Hydraulic, Brake Auto Adjuster, Anti-lock Brake System (ABS)					
停車手制 Parking	後輪彈簧制動器 Spring Brake Actuators Acting on Rear Wheels					
輔助制動 Auxiliary	廢氣刹車, 斜坡起動輔助系統(HSA) Exhaust Brake, Hill-Start-Aid (HSA)					
車陣 Frame						
類型 Type	梯型車陣 Ladder Type					
陣闊(毫米) Width (mm)	840					
輪胎及車輪 Tire & Wheel						
車胎 Tire	265/70R19.5 無內膽原子胎			265/70R19.5 Tubeless Radial Tire		
車輪 Wheel	19.5 x 6.75 (8 螺絲)			19.5 x 6.75 (8 Studs)		
標準裝備 Standard Equipment						
	原廠冷氣, 駕駛席SRS安全氣囊 AM/FM收音連CD機, 車門轉向輔助燈 可揭式駕駛室, 避震駕駛室, 電動車窗, 中央門鎖 電動調較角度及電動摺鏡臂(乘客座), 發熱線後鏡 Factory Built Air Conditioner, SRS Airbag on Driver Side AM/FM CD Player, Door Mount Cornering Lamps Tiltable and Cushioning Cab, Power Windows, Central Door Lock Electronic Adjustable and Retractable Side Mirror (Passenger Side), Heated Side Mirrors					

以上規格只供參考。如有更改, 恕不另行通告。

062018

FSR90L-VI / FSR90N-VI / FSR90Q-VI
FSR90LF-VI / FSR90NF-VI / FSR90QF-VI

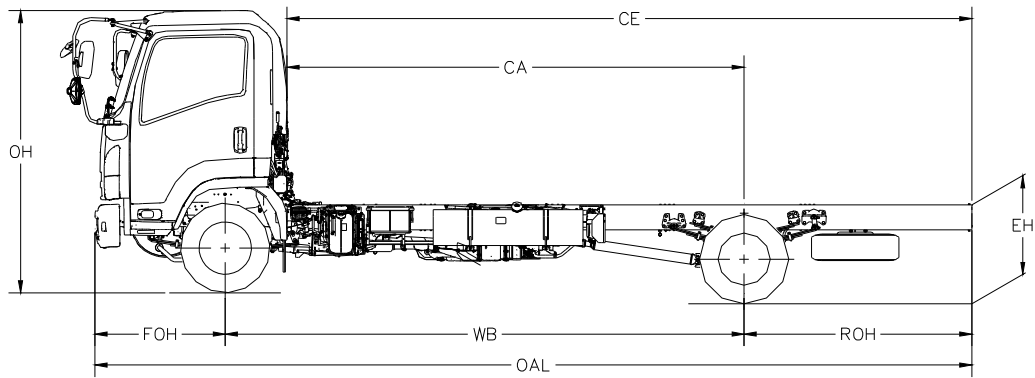
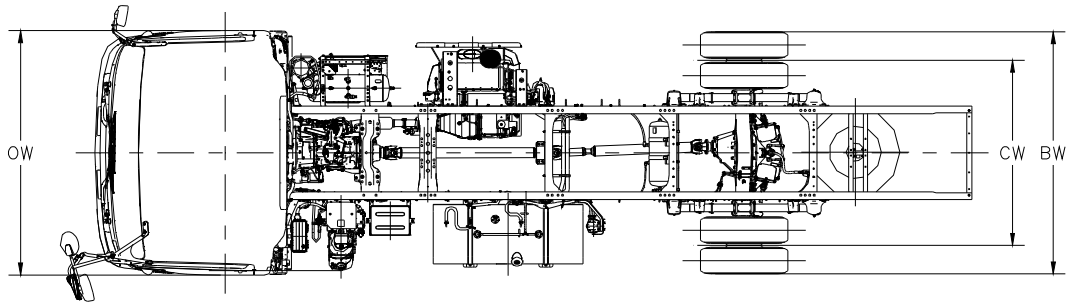

型號 (Model)	OAL	WB	FOH	ROH	CE	CA	OW	BW	CW	OH Approx	EH Approx	
FSR90L-VI/ FSR90LF-VI	7225 284.4	4360 171.7	1170 46.1	1725 67.9	5189 204.3	3464 136.4	2200 86.6	2260 89.0	1705 67.1	2600 102.4	915 36.0	毫米 (mm) 寸 (in)
FSR90N-VI/ FSR90NF-VI	8155 321.1	4860 191.3	1170 46.1	2125 83.7	6089 239.7	3964 156.1	2200 86.6	2260 89.0	1705 67.1	2600 102.4	915 36.0	毫米 (mm) 寸 (in)
FSR90Q-VI/ FSR90QF-VI	9155 360.4	5560 218.9	1170 46.1	2425 95.5	7089 279.1	4664 183.6	2200 86.6	2260 89.0	1705 67.1	2600 102.4	915 36.0	毫米 (mm) 寸 (in)

以上尺寸只供參考。如有更改，恕不另行通告。