

全新五十鈴環保6型 16噸車陣

型號 Model	FVR34 手波型號			FVR34 全自動波型號		
	FVR34MC-VI-C	FVR34QC-VI-C	FVR34SC-VI-C	FVR34MC-VI-AT-C	FVR34QC-VI-AT-C	FVR34SC-VI-AT-C
廢氣排放標準 Emission Standard	環保六型 Euro VI					
總重量(公斤) G.V.W. (kg)	16,000					
乘客量(連司機) Seating Capacity	1 + 2 座位 (FULL CAB)					
車身尺寸 Dimensions						
全長(毫米) Overall Length (mm)	7,955	9,255	10,005	7,955	9,255	10,005
全闊(毫米) Overall Width (mm)	2,480	2,480	2,480	2,480	2,480	2,480
全高(毫米) Overall Height (mm)	2,800	2,800	2,800	2,800	2,800	2,800
輪距(毫米) Wheelbase (mm)	4,650	5,550	6,050	4,650	5,550	6,050
引擎 Engine						
型號 Model	6HK1-E6S					
類別 Type	直列式六氣缸，24氣閥，可變活瓣渦輪增壓 (DVNT Turbo)連中置冷卻器， 廢氣再循環裝置 (EGR)，電子控制高壓共軌噴注系統 (CRS)， 柴油微粒過濾器+選擇性催化還原 (DPD+SCR) In-line, 6 Cylinders, 24 Valves, Variable Geometry System Turbocharger (VGS Turbo) with Intercooler Exhaust Gas Recirculation (EGR), Common Rail System (CRS), Diesel Particulate Diffuser (DPD) + Selective Catalytic Reduction (SCR)					
汽缸容積(毫升) Displacement (cc)	7,790					
最大馬力(匹/轉) Max. Output (PS/rpm)	275 / 2,400					
最大扭力(公斤-米/轉) Max. Torque (kgm/rpm)	100 / 1,450					
油缸容積(公升) Fuel Tank Capacity (litre)	400					
尿素缸容積(公升) Adblue Tank Capacity (litre)	28					
波箱 Transmission						
型號 Model	EATON ESO-11306A 6前1後 手動波箱 6 Forward 1 Reverse, Manual			ALLISON MD3060 6前1後 全自動波箱 6 Forward 1 Reverse, Automatic		
波段比 Gear Ratios	1 ~ 6波 : 7.05 ~ 0.78			1 ~ 6波 : 3.486 ~ 0.652		
最終傳動比 Final Gear Ratio	5.571			6.5		
離合器 Clutch						
類別 Type	單乾板式附避震彈簧，空氣輔助液壓控制 Dry Single Plate with Cushioning Spring, Hydraulic Control with Air Assisted			扭力轉換器 TC-418 Torque Converter TC-418		
轉向系統 Steering						
類型 Type	走珠式動力輔助轉向系統 Recirculating Ball with Power Assisted					
懸掛系統 Suspension						
前懸掛 Front	半橢圓鋼合金多層葉片式彈簧，雙重液壓吸震筒，防滾桿 Semi-elliptical, Alloy Steel Leaf Spring, Double Acting Telescopic Shock Absorber, Anti-roll Bar					
後懸掛 Rear	半橢圓鋼合金多層葉片式彈簧 Semi-elliptical, Alloy Steel Leaf Spring					
前軸 Front Axle	倒置愛里奧工字架 Reverse Elliot "I" Beam					
廠方設計負重(公斤) Design Axle Loading (kg)	6,300					
運輸署批核負重(公斤) Allocated Weight (kg)	6,300					
後軸 Rear Axle	琵琶型全浮式 Banjo, Full Floating Type					
廠方設計負重(公斤) Design Axle Loading (kg)	10,500					
運輸署批核負重(公斤) Allocated Weight (kg)	10,000					
制動系統 Brake						
制動操作 Service	前後鼓刹，全風雙管路楔式制動，虛位自動調節器，ABS防鎖制車系統 Front&Rear Drum, Full Air, Dual Circuit, Wedge Type, Brake Auto Adjuster, Anti-lock Brake System (ABS)					
停車手制 Parking	後輪彈簧制動器 Spring Brake Actuators Acting on Rear Wheels					
輔助制動 Auxiliary	廢氣制車，斜坡起動輔助系統(HSA) Exhaust Brake, Hill-Start-Aid (HSA)			廢氣制車 Exhaust Brake		
車陣 Frame						
類型 Type	梯型車陣 Ladder Type					
陣闊(毫米) Width (mm)	850					
輪胎及車輪 Tire&Wheel						
車胎 Tire	11R22.5 無內膽原子胎			11R22.5 Tubeless Radial Tire		
車輪 Wheel	22.5 x 7.50 (10 螺絲)			22.5 x 7.50 (10 Studs)		
標準裝備 Standard Equipment						
	原廠冷氣，駕駛席SRS安全氣囊 AM/FM收音連CD機，車門轉向輔助燈 可揭式駕駛室，避震駕駛室，電動車窗，中央門鎖 電動調節角度及電動摺鏡臂(乘客座)，發熱線倒後鏡 HID車頭燈，飛輪取力器(選配) Factory Built Air Conditioner, SRS Airbag on Driver Side AM/FM CD Player, Door Mount Cornering Lamps Tilttable and Cushioning Cab, Power Windows, Central Door Lock Electronic Adjustable and Retractable Side Mirror (Passenger Side), Heated Side Mirrors HID Headlamp, Flywheel PTO (Optional)					

以上規格只供參考。如有更改，恕不另行通告。

062019

FVR34MC-VI / FVR34QC-VI / FVR34SC-VI
FVR34MC-VI-AT / FVR34QC-VI-AT / FVR34SC-VI-AT

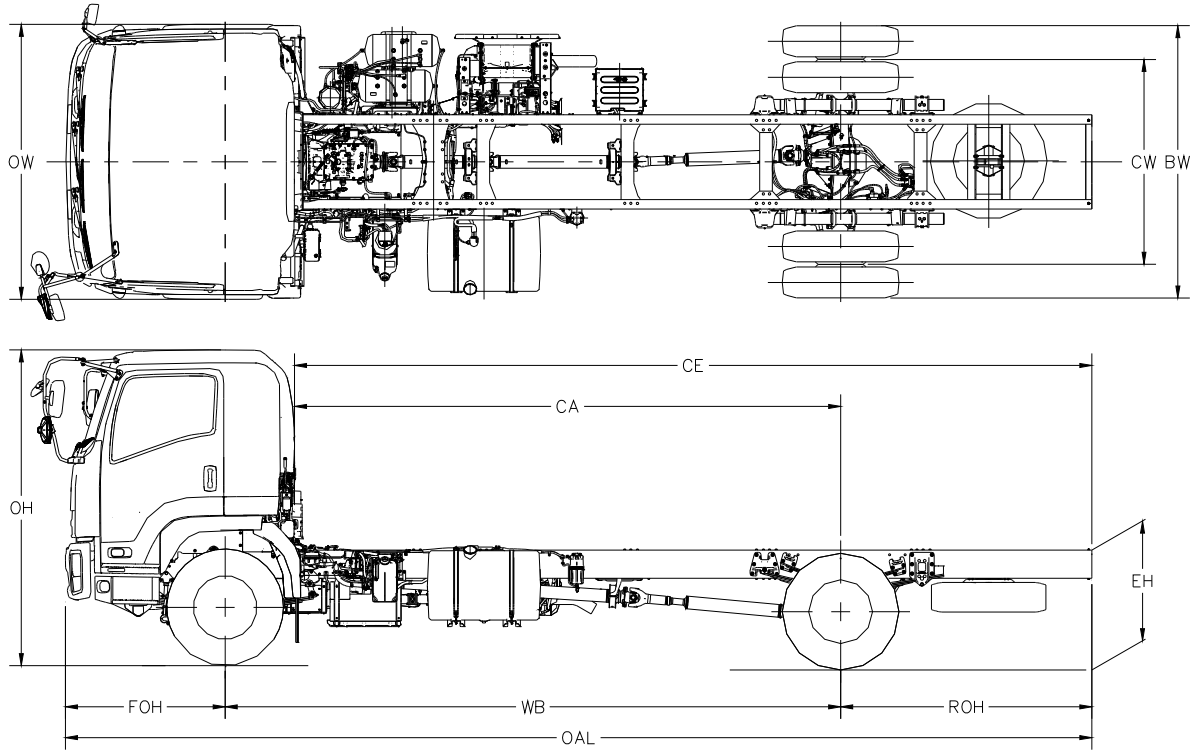

型號 (Model)	OAL	WB	FOH	ROH	CE	CA	OW	BW	CW	OH Approx	EH Approx	
FVR34MC-VI-C/ FVR34MC-VI-AT-C	7955 313.2	4650 183.1	1440 56.7	1865 73.4	5889 231.9	4024 158.4	2480 97.6	2455 96.7	1845 72.6	2800 110.2	1095 43.1	毫米 (mm) 寸 (in)
FVR34QC-VI-C/ FVR34QC-VI-AT-C	9255 364.4	5550 218.5	1440 56.7	2265 89.2	7189 283.0	4924 193.9	2480 97.6	2455 96.7	1845 72.6	2800 110.2	1095 43.1	毫米 (mm) 寸 (in)
FVR34SC-VI-C/ FVR34SC-VI-AT-C	10005 393.9	6050 238.2	1440 56.7	2515 99.0	7939 312.6	5424 213.5	2480 97.6	2455 96.7	1845 72.6	2800 110.2	1095 43.1	毫米 (mm) 寸 (in)

以上尺寸只供參考。如有更改，恕不另行通告。