

## 全新五十鈴環保6型 24噸貨車陣 (輕量版)

FXZ77 手波型號	
<b>型號 Model</b>	FXZ77SX-7S-VI
廢氣排放標準 Emission Standard	環保六型 Euro VI
總重量(公斤) G.V.W. (kg)	24,000
乘客量 (連司機) Seating Capacity	1 + 2 座位
<b>車身尺寸 Dimensions</b>	
全長 (毫米) Overall Length (mm)	10,775
全闊 (毫米) Overall Width (mm)	2,490
全高 (毫米) Overall Height (mm)	2,990
輪距 (毫米) Wheelbase (mm)	5,730
<b>引擎 Engine</b>	
型號 Model	6UZ1E6C
類別 Type	直列式六氣缸，24氣閥，可變活瓣渦輪增壓 (VGS Turbo)連中置冷卻器， 廢氣再循環裝置 (EGR)，電子控制高壓共軌噴注系統 (CRS) 柴油微粒過濾器+選擇性催化還原 (DPD+SCR) In-line, 6 Cylinders, 24 Valves, Variable Geometry System Turbocharger (VGS Turbo) with Intercooler Exhaust Gas Recirculation (EGR), Common Rail System (CRS), Diesel Particulate Diffuser (DPD) + Selective Catalytic Reduction (SCR)
汽缸容積 (毫升) Displacement (cc)	9,839
最大馬力 (匹/轉) Max. Output (PS/rpm)	350 / 2,000
最大扭力 (公斤-米/轉) Max. Torque (kgm/rpm)	145 / 1,400
油缸容積 (公升) Fuel Tank Capacity (litre)	400
尿素缸容積 (公升) Adblue Tank Capacity (litre)	28
<b>波箱 Transmission</b>	
型號 Model	MIT7U 7前1後 手動波箱 7 Forward 1 Reverse, Manual
波段比 Gear Ratios	1 ~ 7波 : 7.740 ~ 0.775
最終傳動比 Final Gear Ratio	4.875
<b>離合器 Clutch</b>	
類別 Type	單乾板式附避震彈簧，空氣輔助液壓控制 Dry Single Plate with Cushioning Spring, Hydraulic Control with Air Assisted
<b>轉向系統 Steering</b>	
類型 Type	走珠式動力輔助轉向系統 Recirculating Ball with Power Assisted
<b>懸掛系統 Suspension</b>	
前懸掛 Front	龍船葉片式彈簧，雙重液壓吸震筒 Taper Leaf Spring, Double Acting Telescopic Shock Absorber
後懸掛 Rear	龍船葉片式彈簧 Taper Leaf Spring
前軸 Front Axle	倒置愛里奧工字架 Reverse Elliot "I" Beam
廠方設計負重 (公斤) Design Axle Loading (kg)	7,500
運輸署批核負重 (公斤) Allocated Weight (kg)	7,100
後軸 Rear Axle	琵琶全浮內擺線齒輪 Banjo, Full Floating Type, Hypoid Gear
廠方設計負重 (公斤) Design Axle Loading (kg)	10,500 + 10,500
運輸署批核負重 (公斤) Allocated Weight (kg)	9,000 + 9,000
<b>制動系統 Brake</b>	
制動操作 Service	前後鼓剎，全風雙管路楔式制動，虛位自動調節器，ABS防鎖剎車系統 Front&Rear Drum, Full Air, Dual Circuit, Wedge Type, Brake Auto Adjuster, Anti-lock Brake System (ABS)
停車手制 Parking	後輪彈簧制動器 Spring Brake Actuators Acting on Rear Wheels
輔助制動 Auxiliary	廢氣剎車 Exhaust Brake
<b>車陣 Frame</b>	
類型 Type	梯型車陣 Ladder Type
陣闊 (毫米) Width (mm)	850
<b>輪胎及車輪 Tire&amp;Wheel</b>	
車胎 Tire	295/80R22.5 無內膽原子胎 295/80R22.5 Tubeless Radial Tire
車輪 Wheel	22.5 x 8.25 (10 螺絲) 22.5 x 8.25 (10 Studs)
<b>標準裝備 Standard Equipment</b>	
	原廠冷氣，電腦錶板多功能顯示器(MID) AM/FM收音連CD機，駕駛席SRS安全氣囊 後輪差速器鎖，電動揭屋仔，避震駕駛室， 氣墊座椅(駕駛座)，車門轉向輔助燈 電動車窗，中央門鎖 Factory Built Air Conditioner, Multi-Information Display (MID) AM/FM CD Player, SRS Airbag on Driver Side Differential Lock, Electrical Driven Tilt Cab, Cushioning Cab Air Suspension Driver's Seat, Door Mount Cornering Lamps Power Windows, Central Door Lock

以上規格只供參考。如有更改，恕不另行通告。

062018

# FXZ77SX-7S-VI

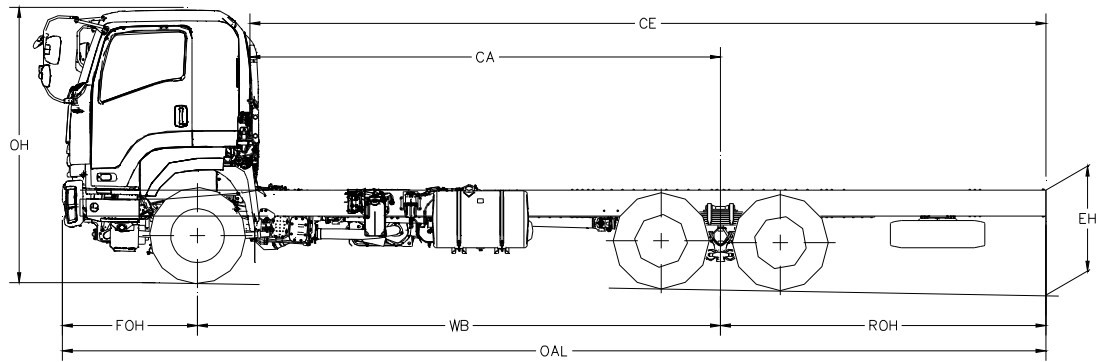
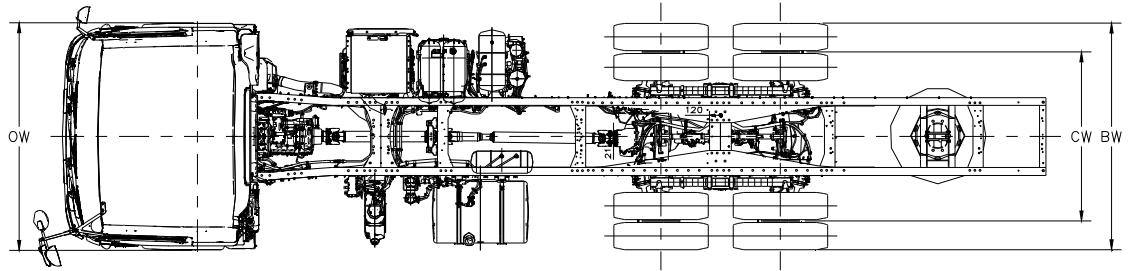

型號 (Model)	OAL	WB	FOH	ROH	CE	CA	OW	BW	CW	OH Approx	EH Approx	
FXZ77SX-7S-VI	10775	5730	1480	3565	8719	5154	2490	2475	1850	2990	1093	毫米 (mm)
	424.2	225.6	58.3	140.4	343.3	202.9	98.0	97.4	72.8	117.7	43.0	寸 (in)

以上尺寸只供參考。如有更改，恕不另行通告。