

## 全新五十鈴環保6型 30噸混凝土車陣 (輕量版)

型號 Model	FYH77 手波型號 FYH77SM-Z9S-VI-C	FYH77 全自動波型號 FYH77SM-6S-VI-AT-C
廢氣排放標準 Emission Standard	環保六型 Euro VI	
總重量(公斤) G.V.W. (kg)	30,000	
乘客量 (連司機) Seating Capacity	1 + 1 座位	
車身尺寸 Dimensions		
全長(毫米) Overall Length (mm)	9,040	
全闊(毫米) Overall Width (mm)	2,490	
全高(毫米) Overall Height (mm)	3,010	3,005
輪距(毫米) Wheelbase (mm)	5,770	
引擎 Engine		
型號 Model	6UZ1E6C	
類別 Type	直列式六氣缸，24氣閥，可變活瓣渦輪增壓 (VGS Turbo)連中置冷卻器， 廢氣再循環裝置 (EGR)，電子控制高壓共軌噴注系統 (CRS) 柴油微粒過濾器+選擇性催化還原 (DPD+SCR) In-line, 6 Cylinders, 24 Valves, Variable Geometry System Turbocharger (VGS Turbo) with Intercooler Exhaust Gas Recirculation (EGR), Common Rail System (CRS), Diesel Particulate Diffuser (DPD) + Selective Catalytic Reduction (SCR)	
汽缸容積(毫升) Displacement (cc)	9,839	
最大馬力(匹轉) Max. Output (PS/rpm)	350 / 2,000	
最大扭力(公斤-米轉) Max. Torque (kgm/rpm)	145 / 1,400	
油缸容積(公升) Fuel Tank Capacity (litre)	200	200
尿素缸容積(公升) Adblue Tank Capacity (litre)	28	
波箱 Transmission		
型號 Model	ZF9S1310 9前1後 手動波箱 9 Forward 1 Reverse, Manual	ALLISON 4430 6前1後 全自動波箱 6 Forward 1 Reverse, Automatic
波段比 Gear Ratios	1 ~ 9波 : 9.479 ~ 0.752	1 ~ 6波 : 4.70 ~ 0.67
最終傳動比 Final Gear Ratio	5.571	5.125
離合器 Clutch		
類別 Type	單乾板式附避震彈簧，空氣輔助液壓控制 Dry Single Plate with Cushioning Spring, Hydraulic Control with Air Assisted	扭力轉換器 TC531 (傳動比: 2.34) Torque Converter TC531 (Drive Ratio: 2.34)
轉向系統 Steering		
類型 Type	走珠式動力輔助轉向系統 Recirculating Ball with Power Assisted	
懸掛系統 Suspension		
前懸掛 Front	龍船葉片式彈簧，雙重液壓吸震筒 Taper Leaf Spring, Double Acting Telescopic Shock Absorber	
後懸掛 Rear	龍船葉片式彈簧 Taper Leaf Spring	
前軸 Front Axle	倒置愛里奧工字架 Reverse Elliot "I" Beam	
廠方設計負重(公斤) Design Axle Loading (kg)	6,600 + 6,600	
運輸署批核負重(公斤) Allocated Weight (kg)	6,300 + 6,300	
後軸 Rear Axle	琵琶全浮內擺線齒輪 Banjo, Full Floating Type, Hypoid Gear	
廠方設計負重(公斤) Design Axle Loading (kg)	10,500 + 10,500	
運輸署批核負重(公斤) Allocated Weight (kg)	9,000 + 9,000	
制動系統 Brake		
制動操作 Service	前後鼓剎，全風雙管路楔式制動，虛位自動調節器，ABS防鎖剎車系統 Front&Rear Drum, Full Air, Dual Circuit, Wedge Type, Brake Auto Adjuster, Anti-lock Brake System (ABS)	
停車手制 Parking	後輪彈簧制動器 Spring Brake Actuators Acting on Rear Wheels	
輔助制動 Auxiliary	廢氣剎車 Exhaust Brake	
車陣 Frame		
類型 Type	梯型車陣 Ladder Type	
陣闊(毫米) Width (mm)	850	
輪胎及車輪 Tire&Wheel		
車胎 Tire	11R22.5 無內膽原子胎	11R22.5 Tubeless Radial Tire
車輪 Wheel	22.5 x 8.25 (10 螺絲)	22.5 x 8.25 (10 Stud)
標準裝備 Standard Equipment		
	原廠冷氣，電腦錶板多功能顯示器(MID) AM/FM收音連CD機，駕駛席SRS安全氣囊 後輪差速器鎖，電動揭屋仔，避震駕駛室， 氣墊座椅(駕駛座)，車門轉向輔助燈，電動車窗，中央門鎖 鋁合金油缸，鋁合金輪圈 Factory Built Air Conditioner, Multi-Information Display (MID) AM/FM CD Player, SRS Airbag on Driver Side Differential Lock, Electrical Driven Tilt Cab, Cushioning Cab Air Suspension Driver's Seat, Door Mount Cornering Lamps, Power Windows, Central Door Lock Aluminium Fuel Tank, Aluminium Wheel	

以上規格只供參考。如有更改，恕不另行通告。

062019

FYH77SM-Z9S-VI-C / FYH77SM-6S-VI-AT-C

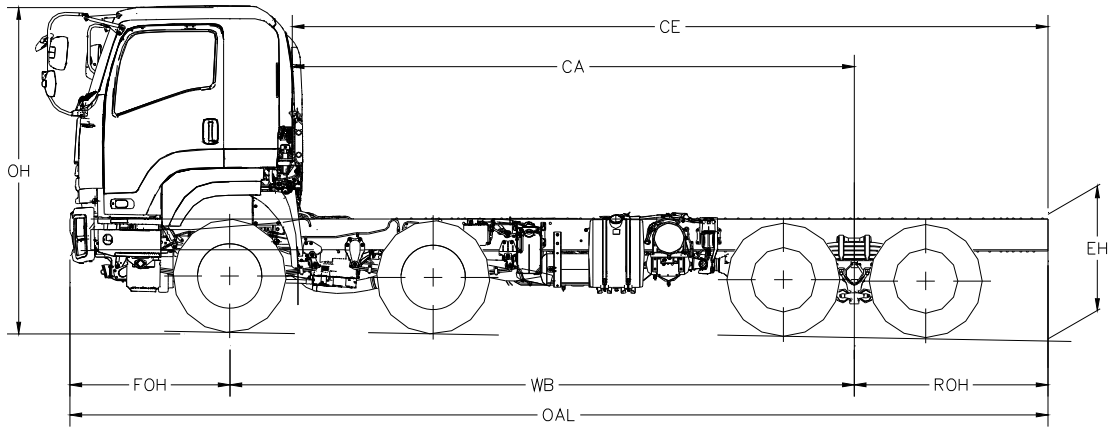
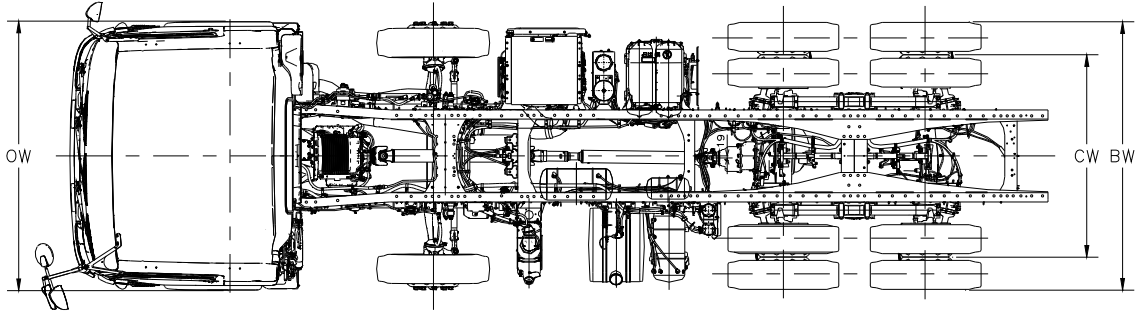

型號 (Model)	OAL	WB	FOH	ROH	CE	CA	OW	BW	CW	OH Approx	EH Approx	
FYH77SM-Z9S-VI-C / FYH77SM-6S-VI-AT-C	9040	5770	1480	1790	6984	5194	2490	2475	1850	3010	1105	毫米 (mm)
	356	227	58	70	270	200	98	97	73	119	43	寸 (in)

以上尺寸只供參考。如有更改，恕不另行通告。