

全新五十鈴環保6型 3.5噸車陣

	NHR87 手波型號
型號 Model	NHR87E-VI-C
廢氣排放標準 Emission Standard	環保六型 Euro 6
總重量(公斤) G.V.W. (kg)	3,500
乘客量(連司機) Seating Capacity	1 + 2 座位
車身尺寸 Dimensions	
全長(毫米) Overall Length (mm)	4,630
全闊(毫米) Overall Width (mm)	1,695
全高(毫米) Overall Height (mm)	1,970
輪距(毫米) Wheelbase (mm)	2,500
引擎 Engine	
型號 Model	RZ4EE6R-T
類別 Type	直列四汽缸，雙頂凸輪軸，可變活瓣渦輪增壓 (VGS Turbo)連中置冷卻器， 廢氣再循環裝置 (EGR)，電子控制高壓共軌噴注系統 (CRS)， 稀油氮氧化物捕集器+柴油微粒過濾器+選擇性催化還原(LNT+DPD+SCR) In-line, 4 Cylinders, DOHC, Variable Geometry System Turbocharger (VGS Turbo) with Intercooler Exhaust Gas Recirculation (EGR), Common Rail System (CRS), Lean NOx Trap (LNT) +Diesel Particulate Diffuser (DPD)+Selective Catalytic Reduction (SCR)
汽缸容積(毫升) Displacement (cc)	1,898
最大馬力(匹/轉) Max. Output (PS/rpm)	120 / 3,000 ~ 3,200
最大扭力(公斤-米/轉) Max. Torque (kgm/rpm)	32.6 / 1,600 - 2,000
油缸容積(公升) Fuel Tank Capacity (litre)	68
尿素缸容積(公升) Adblue Tank Capacity (litre)	10
波箱 Transmission	
型號 Model	MVC6W 6前1後 手動波箱 6 Forward 1 Reverse, Manual
波段比 Gear Ratios	1 ~ 6波: 4.942 ~ 0.634
最終傳動比 Final Gear Ratio	3.909
離合器 Clutch	
類別 Type	單乾板式附避震彈簧，真空液壓輔助控制 Dry Single Plate with Cushioning Spring, Vacuum Control
轉向系統 Steering	
類型 Type	齒輪齒條轉向系統 Power assisted, Rack and Pinion Steering System
懸掛系統 Suspension	
前懸掛 Front	獨立搖臂配橫向式彈簧片，雙重液壓吸震筒 Independent Wishbone, Leaf Spring, Double Acting Telescopic Shock Absorber
後懸掛 Rear	半橢圓鋼合金葉片式彈簧，雙重液壓吸震筒 Semi-elliptical, Alloy Steel Leaf Spring, Double Acting Telescopic Shock Absorber
前軸 Front Axle	倒置愛里奧工字架 Reverse Elliot "I" Beam
廠方設計負重(公斤) Design Axle Loading (kg)	1,900
運輸署批核負重(公斤) Allocated Weight (kg)	1,900
後軸 Rear Axle	琵琶型全浮式 Banjo, Full Floating Type
廠方設計負重(公斤) Design Axle Loading (kg)	2,100
運輸署批核負重(公斤) Allocated Weight (kg)	2,100
制動系統 Brake	
制動操作 Service	前碟後鼓，真空輔助油壓式制動，ABS防鎖制車系統 Front Disc, Rear Drum, Vacuum Servo Hydraulic, Anti-lock Brake System (ABS)
停車手制 Parking	機械式傳動輸出軸制動 Mechanical Parking Brake on Propeller Shaft
車陣 Frame	
類型 Type	梯型車陣 Ladder Type
陣闊(毫米) Width (mm)	700
輪胎及車輪 Tire&Wheel	
車胎 Tire	185/75R15 無內膽原子胎(前輪) 185/75R15 Tubeless Radial Tire (Front) 155R13-8 無內膽原子胎(後輪) 155R13-8 Tubeless Radial Tire (Rear)
車輪 Wheel	15 x 5 (5 螺絲)(前輪) 15 x 5 (5 Studs) (Front) 13 x 4 (4 螺絲)(後輪) 13 x 4 (4 Studs) (Rear)
標準裝備 Standard Equipment	
	原廠冷氣，12V-150A發電機，駕駛席SRS安全氣囊 頭霧燈，可揭式駕駛室，電動車窗，中央門鎖，後備輪呔 Factory Built Air Conditioner, 12V-150A Generator, SRS Airbag on Driver Side Front Fog Lamp, Tilttable Cab, Power Windows, Central Door Lock, Spare Tire

以上規格只供參考。如有更改，恕不另行通告。

082020

NHR87E-VI-C

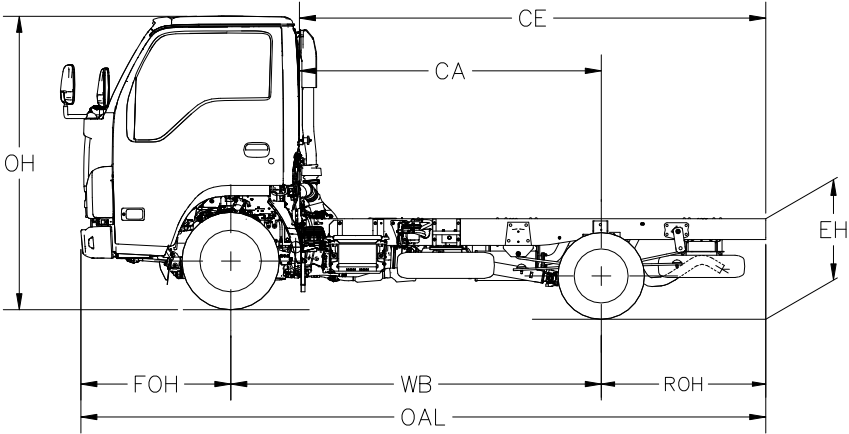
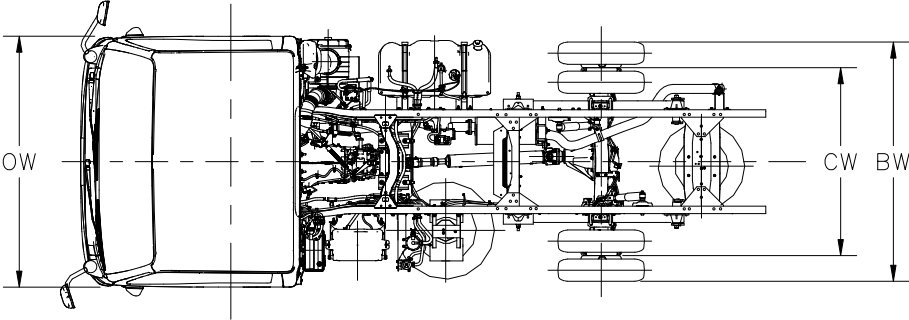

型號 (Model)	OAL	WB	FOH	ROH	CE	CA	OW	BW	CW	OH Approx	EH Approx	
NHR87E-VI-C	4630	2500	1015	1105	3147	2037	1695	1600	1265	1970	677	毫米 (mm)
	182.3	98.4	40.0	43.5	123.9	80.2	66.7	63.0	49.8	77.6	26.7	寸 (in)

以上尺寸只供參考。如有更改，恕不另行通告。