

全新五十鈴環保6型 5.2噸車陣

型號 Model	NMR85 手波型號		NMR85 Smoother-Ex 電子自動波型號	
	NMR85F-VI	NMR85H-VI	NMR85FE-VI	NMR85HE-VI
廢氣排放標準 Emission Standard	環保六型 Euro VI			
總重量(公斤) G.V.W. (kg)	5,200			
乘客量 (連司機) Seating Capacity	1 + 2 座位			
車身尺寸 Dimensions				
全長(毫米) Overall Length (mm)	5,250	6,020	5,250	6,020
全闊(毫米) Overall Width (mm)	1,865	1,865	1,865	1,865
全高(毫米) Overall Height (mm)	2,160	2,160	2,160	2,160
輪距(毫米) Wheelbase (mm)	2,750	3,350	2,750	3,350
引擎 Engine				
型號 Model	4JJ1-E6N			
類別 Type	直列式四氣缸，16氣閥，可變活瓣渦輪增壓(VGS Turbo)連中置冷卻器， 廢氣再循環裝置(EGR)，電子控制高壓共軌噴注系統(CRS)， 柴油微粒過濾器+選擇性催化還原(DPD+SCR) In-line, 4 Cylinders, 16 Valves, Variable Geometry System Turbocharger (VGS Turbo) with Intercooler Exhaust Gas Recirculation (EGR), Common Rail System (CRS), Diesel Particulate Diffuser (DPD) + Selective Catalytic Reduction (SCR)			
汽缸容積(毫升) Displacement (cc)	2,999			
最大馬力(匹/轉) Max. Output (PS/rpm)	150 / 2,800			
最大扭力(公斤-米/轉) Max. Torque (kgm/rpm)	38.2 / 1,600 - 2,800			
油缸容積(公升) Fuel Tank Capacity (litre)	75	100	75	100
尿素缸容積(公升) Adblue Tank Capacity (litre)	16			
波箱 Transmission				
型號 Model	MYY5T 5前1後 手動波箱 5 Forward 1 Reverse, Manual		MYY6S 6前1後 "+/-"式電子自動波箱 6 Forward 1 Reverse, Smoother Ex "+/-" Automatic Shifting Device	
波段比 Gear Ratios	1 ~ 5波 : 5.315 ~ 0.721		1 ~ 6 波 : 5.979 ~ 0.759	
最終傳動比 Final Gear Ratio	5.125		4.3	
離合器 Clutch				
類別 Type	單乾板式附避震彈簧，真空液壓輔助控制 Dry Single Plate with Cushioning Spring, Vacuum Control		濕式多板離合器 Wet Type Multi Plate	
轉向系統 Steering				
類型 Type	走珠式動力輔助轉向系統 Recirculating Ball with Power Assisted			
懸掛系統 Suspension				
前懸掛 Front	龍船葉片式彈簧，雙重液壓吸震筒 Taper Leaf Spring, Double Acting Telescopic Shock Absorber			
後懸掛 Rear	半橢圓鋼合金多層葉片式彈簧，雙重液壓吸震筒，防滾桿 Semi-elliptical, Alloy Steel Leaf Spring, Double Acting Telescopic Shock Absorber, Anti-roll Bar			
前軸 Front Axle	倒置愛里奧工字架 Reverse Elliot "I" Beam			
廠方設計負重(公斤) Design Axle Loading (kg)	2,900			
運輸署批核負重(公斤) Allocated Weight (kg)	2,360			
後軸 Rear Axle	琵琶型全浮式 Banjo, Full Floating Type			
廠方設計負重(公斤) Design Axle Loading (kg)	5,000			
運輸署批核負重(公斤) Allocated Weight (kg)	4,480			
制動系統 Brake				
制動操作 Service	前碟後鼓式，真空輔助油壓式制動，ABS防鎖剎車系統 Front Disc, Rear Drum, Vacuum Servo Hydraulic, Anti-lock Brake System (ABS)			
停車手制 Parking	機械式傳動輸出軸制動 Mechanical Parking Brake on Propeller Shaft			
輔助制動 Auxiliary	廢氣剎車，電子制動力分佈系統(EBD)， 斜坡起動輔助系統(HSA)，防滑控制(ASR) Exhaust Brake, Electronic Braking Force Distribution (EBD), Hill-Start-Aid (HSA), Anti-Slip Regulator (ASR)		廢氣剎車，電子制動力分佈系統(EBD)， 防滑控制(ASR) Exhaust Brake, Electronic Braking Force Distribution (EBD), Anti-Slip Regulator (ASR)	
車陣 Frame				
類型 Type	梯型車陣 Ladder Type			
陣闊(毫米) Width (mm)	700			
輪胎及車輪 Tire & Wheel				
車胎 Tire	195/85R16 無內膽原子胎		195/85R16 Tubeless Radial Tire	
車輪 Wheel	16 x 5.5 (5 螺絲)		16 x 5.5 (5 Studs)	
標準裝備 Standard Equipment				
	原廠冷氣，駕駛席SRS安全氣囊 AM/FM收音連CD機，車門轉向輔助燈， 可揭式駕駛室，避震駕駛室，電動車窗，中央門鎖 Factory Built Air Conditioner, SRS Airbag on Driver Side AM/FM CD Player, Door Mount Cornering Lamps Tilttable and Cushioning Cab, Power Windows, Central Door Lock			

以上規格只供參考。如有更改，恕不另行通告。

062018

NMR85F-VI / NMR85FE-VI

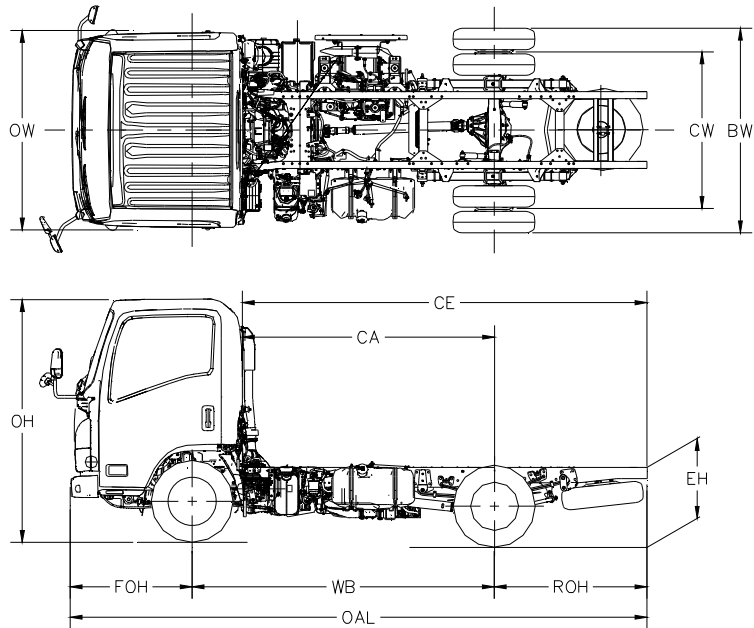

型號 (Model)	OAL	WB	FOH	ROH	CE	CA	OW	BW	CW	OH Approx	EH Approx	
NMR85F-VI/ NMR85FE-VI	5250	2750	1110	1390	3687	2297	1815	1865	1425	2160	727	毫米 (mm)
	206.7	108.3	43.7	54.7	145.2	90.4	71.5	73.4	56.1	85.0	28.6	寸 (in)

NMR85H-VI / NMR85HE-VI

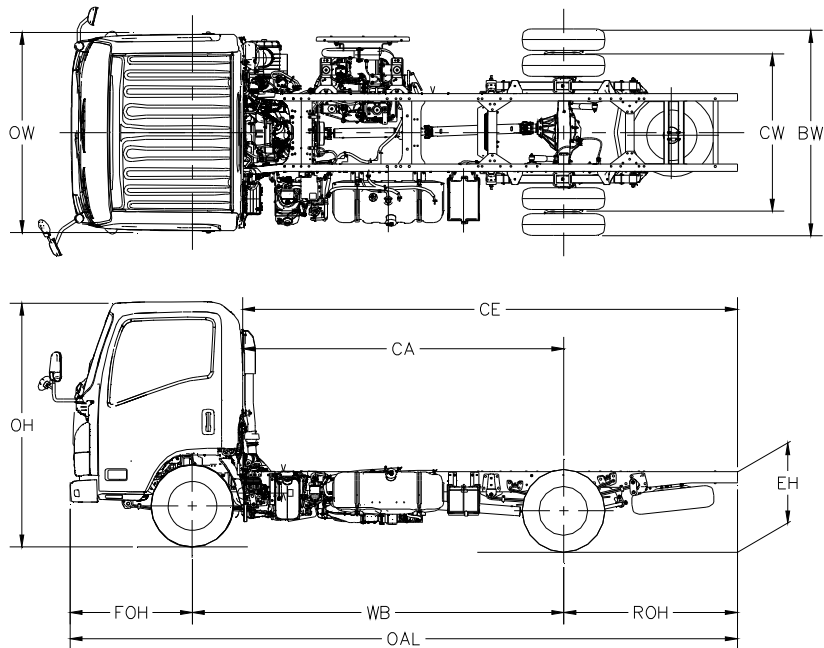

型號 (Model)	OAL	WB	FOH	ROH	CE	CA	OW	BW	CW	OH Approx	EH Approx	
NMR85H-VI/ NMR85HE-VI	6020	3350	1110	1560	4462	2897	1815	1865	1425	2160	765	毫米 (mm)
	237.0	131.9	43.7	61.4	175.7	114.1	71.5	73.4	56.1	85.0	30.1	寸 (in)

以上尺寸只供參考。如有更改，恕不另行通告。