

## 全新五十鈴環保6型 5.5噸車陣

型號 Model	NPR75 手波型號			NPR75 Smoother-Ex 電子自動波型號		
	NPR75FH-VI	NPR75HH-VI	NPR75KH-VI	NPR75FHE-VI	NPR75HHE-VI	NPR75KHE-VI
廢氣排放標準 Emission Standard	環保六型 Euro VI					
總重量(公斤) G.V.W. (kg)	5,500					
乘客量(連司機) Seating Capacity	1 + 2 座位					
<b>車身尺寸 Dimensions</b>						
全長(毫米) Overall Length (mm)	5,385	5,985	6,635	5,385	5,985	6,635
全闊(毫米) Overall Width (mm)	2,115	2,115	2,115	2,115	2,115	2,115
全高(毫米) Overall Height (mm)	2,245	2,245	2,245	2,245	2,245	2,245
輪距(毫米) Wheelbase (mm)	2,765	3,365	3,815	2,765	3,365	3,815
<b>引擎 Engine</b>						
型號 Model	4HK1-E6C					
類別 Type	直列式四氣缸, 16氣閥, 可變活瓣渦輪增壓 (VGS Turbo) 連中置冷卻器, 廢氣再循環裝置 (EGR), 電子控制高壓共軌噴注系統 (CRS), 柴油微粒過濾器+選擇性催化還原 (DPD+SCR) In-line, 4 Cylinders, 16 Valves, Variable Geometry System Turbocharger (VGS Turbo) with Intercooler Exhaust Gas Recirculation (EGR), Common Rail System (CRS), Diesel Particulate Diffuser (DPD) + Selective Catalytic Reduction (SCR)					
汽缸容積(毫升) Displacement (cc)	5,193					
最大馬力(匹/轉) Max. Output (PS/rpm)	190 / 2,600					
最大扭力(公斤-米/轉) Max. Torque (kgm/rpm)	52 / 1,600 ~ 2,600					
油缸容積(公升) Fuel Tank Capacity (litre)	100					
尿素缸容積(公升) Adblue Tank Capacity (litre)	16					
<b>波箱 Transmission</b>						
型號 Model	MZZ6F 6前1後 手動波箱 6 Forward 1 Reverse, Manual			MZZ6F 6前1後 "+/-"式電子自動波箱 6 Forward 1 Reverse, Smoother Ex "+/-" Automatic Shifting Device		
波段比 Gear Ratios	1 ~ 6波: 6.369 ~ 0.782					
最終傳動比 Final Gear Ratio	4.1					
<b>離合器 Clutch</b>						
類別 Type	單乾板式附避震彈簧, 真空輔助控制 Dry Single Plate with Cushioning Spring, Vacuum Control			濕式多板離合器 Wet Type Multi Plate		
<b>轉向系統 Steering</b>						
類型 Type	走珠式動力輔助轉向系統 Recirculating Ball with Power Assisted					
<b>懸掛系統 Suspension</b>						
前懸掛 Front	半橢圓鋼合金多層葉片式彈簧, 雙重液壓吸震筒, 防滾桿(只限短陣型號) Semi-elliptical, Alloy Steel Leaf Spring, Double Acting Telescopic Shock Absorber, Anti-roll Bar (Short WB only)					
後懸掛 Rear	半橢圓鋼合金多層葉片式彈簧, 雙重液壓吸震筒, 防滾桿 Semi-elliptical, Alloy Steel Leaf Spring, Double Acting Telescopic Shock Absorber, Anti-roll Bar					
前軸 Front Axle	倒置愛里奧工字架 Reverse Elliot "I" Beam					
廠方設計負重(公斤) Design Axle Loading (kg)	3,100					
運輸署批核負重(公斤) Allocated Weight (kg)	2,800					
後軸 Rear Axle	琵琶型全浮式 Banjo, Full Floating Type					
廠方設計負重(公斤) Design Axle Loading (kg)	6,600					
運輸署批核負重(公斤) Allocated Weight (kg)	5,280					
<b>制動系統 Brake</b>						
制動操作 Service	前碟後鼓式, 真空輔助油壓式制動, ABS防鎖剎車系統 Front Disc, Rear Drum, Vacuum Servo Hydraulic, Anti-lock Brake System (ABS)					
停車手制 Parking	機械式傳動軸制動 Mechanical Parking Brake on Propeller Shaft					
輔助制動 Auxiliary	廢氣剎車, 電子制動力分佈系統(EBD), 斜坡起動輔助系統(HSA), 防滑控制(ASR) Exhaust Brake, Electronic Braking Force Distribution (EBD), Hill-Start-Aid (HSA), Anti-Slip Regulator (ASR)			廢氣剎車, 電子制動力分佈系統(EBD), 防滑控制(ASR) Exhaust Brake, Electronic Braking Force Distribution (EBD), Anti-Slip Regulator (ASR)		
<b>車陣 Frame</b>						
類型 Type	梯型車陣 Ladder Type					
陣闊(毫米) Width (mm)	850					
<b>輪胎及車輪 Tire &amp; Wheel</b>						
車胎 Tire	215/85R16 無內膽原子胎			215/85R16 Tubeless Radial Tire		
車輪 Wheel	16 x 6 (6 螺絲)			16 x 6 (6 Studs)		
<b>標準裝備 Standard Equipment</b>						
	原廠冷氣, 駕駛席SRS安全氣囊 AM/FM收音連CD機, 車門轉向輔助燈, 可揭式駕駛室, 避震駕駛室, 電動車窗, 中央門鎖 Factory Built Air Conditioner, SRS Airbag on Driver Side AM/FM CD Player, Door Mount Cornering Lamps Tilttable and Cushioning Cab, Power Windows, Central Door Lock					

以上規格只供參考。如有更改, 恕不另行通告。

062018

## NPR75FH-VI / NPR75FHE-VI

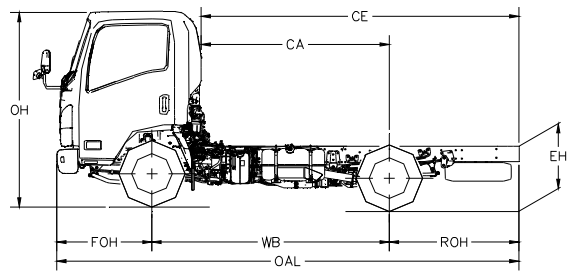
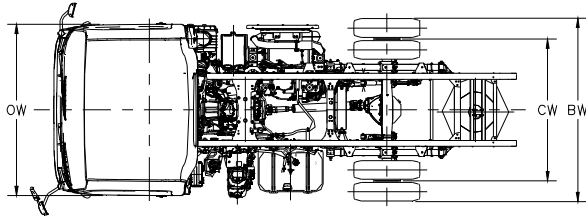

型號 (Model)	OAL	WB	FOH	ROH	CE	CA	OW	BW	CW	OH Approx	EH Approx	
NPR75FH-VI / NPR75FHE-VI	5385	2765	1110	1510	3702	2192	1995	2135	1650	2245	835	毫米 (mm)
	212.0	108.9	43.7	59.4	145.7	86.3	78.5	84.1	65.0	88.4	32.9	寸 (in)

## NPR75HH-VI / NPR75HHE-VI

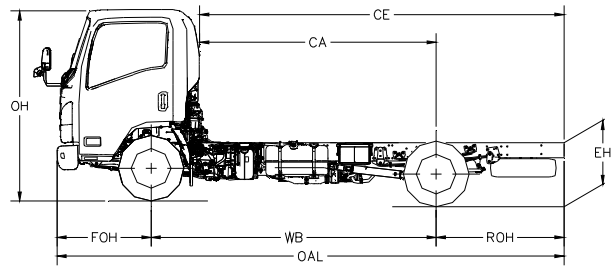
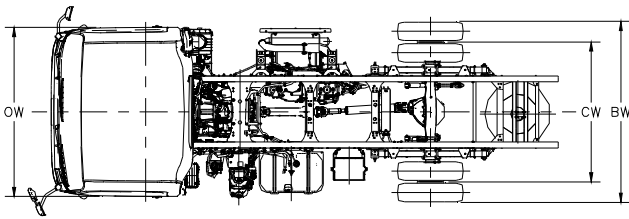

型號 (Model)	OAL	WB	FOH	ROH	CE	CA	OW	BW	CW	OH Approx	EH Approx	
NPR75HH-VI / NPR75HHE-VI	5985	3365	1110	1510	4302	2792	1995	2135	1650	2245	835	毫米 (mm)
	235.6	132.5	43.7	59.4	169.4	109.9	78.5	84.1	65.0	88.4	32.9	寸 (in)

## NPR75KH-VI / NPR75KHE-VI

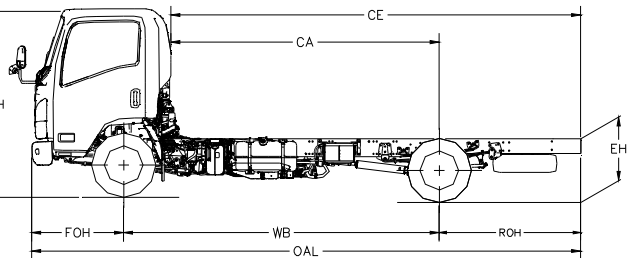
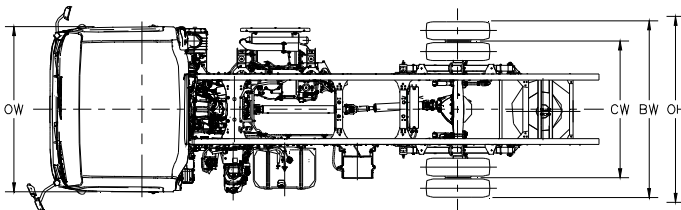

型號 (Model)	OAL	WB	FOH	ROH	CE	CA	OW	BW	CW	OH Approx	EH Approx	
NPR75KH-VI / NPR75KHE-VI	6635	3815	1110	1710	4952	3242	1995	2135	1650	2245	835	毫米 (mm)
	261.2	150.2	43.7	67.3	195.0	127.6	78.5	84.1	65.0	88.4	32.9	寸 (in)

以上尺寸只供參考。如有更改，恕不另行通告。

## 全新五十鈴環保6型 5.5噸車陣(雙排座)

型號 Model	NPR75 手波型號		NPR75 Smoother-Ex 電子自動波型號	
	NPR75HJW-VI	NPR75KJW-VI	NPR75HJWE-VI	NPR75KJWE-VI
廢氣排放標準 Emission Standard	環保六型 Euro VI			
總重量(公斤) G.V.W. (kg)	5,500			
乘客量 (連司機) Seating Capacity	1 + 5 座位			
<b>車身尺寸 Dimensions</b>				
全長(毫米) Overall Length (mm)	5,985	6,635	5,985	6,635
全闊(毫米) Overall Width (mm)	2,115	2,115	2,115	2,115
全高(毫米) Overall Height (mm)	2,245	2,245	2,245	2,245
輪距(毫米) Wheelbase (mm)	3,365	3,815	3,365	3,815
<b>引擎 Engine</b>				
型號 Model	4HK1-E6C			
類別 Type	直列式四氣缸, 16氣閥, 可變活瓣渦輪增壓 (VGS Turbo)連中置冷卻器, 廢氣再循環裝置 (EGR), 電子控制高壓共軌噴注系統 (CRS), 柴油微粒過濾器+選擇性催化還原 (DPD+SCR) In-line, 4 Cylinders, 16 Valves, Variable Geometry System Turbocharger (VGS Turbo) with Intercooler Exhaust Gas Recirculation (EGR), Common Rail System (CRS), Diesel Particulate Diffuser (DPD) + Selective Catalytic Reduction (SCR)			
汽缸容積(毫升) Displacement (cc)	5,193			
最大馬力(匹/轉) Max. Output (PS/rpm)	190 / 2,600			
最大扭力(公斤-米/轉) Max. Torque (kgm/rpm)	52 / 1,600 ~ 2,600			
油缸容積(公升) Fuel Tank Capacity (litre)	100			
尿素缸容積(公升) Adblue Tank Capacity (litre)	16			
<b>波箱 Transmission</b>				
型號 Model	MZZ6F 6前1後 手動波箱 6 Forward 1 Reverse, Manual		MZZ6F 6前1後 "+/-"式電子自動波箱 6 Forward 1 Reverse, Smoother Ex "+/-" Automatic Shifting Device	
波段比 Gear Ratios	1 ~ 6波: 6.369 ~ 0.782			
最終傳動比 Final Gear Ratio	4.1			
<b>離合器 Clutch</b>				
類別 Type	單乾板式附避震彈簧, 真空輔助控制 Dry Single Plate with Cushioning Spring, Vacuum Control		濕式多板離合器 Wet Type Multi Plate	
<b>轉向系統 Steering</b>				
類型 Type	走珠式動力輔助轉向系統 Recirculating Ball with Power Assisted			
<b>懸掛系統 Suspension</b>				
前懸掛 Front	半橢圓鋼合金多層葉片式彈簧, 雙重液壓吸震筒 Semi-elliptical, Alloy Steel Leaf Spring, Double Acting Telescopic Shock Absorber			
後懸掛 Rear	半橢圓鋼合金多層葉片式彈簧, 雙重液壓吸震筒, 防滾桿 Semi-elliptical, Alloy Steel Leaf Spring, Double Acting Telescopic Shock Absorber, Anti-roll Bar			
前軸 Front Axle	倒置愛里奧工字架 Reverse Elliot "I" Beam			
廠方設計負重(公斤) Design Axle Loading (kg)	3,100			
運輸署批核負重(公斤) Allocated Weight (kg)	2,800			
後軸 Rear Axle	琵琶型全浮式 Banjo, Full Floating Type			
廠方設計負重(公斤) Design Axle Loading (kg)	6,600			
運輸署批核負重(公斤) Allocated Weight (kg)	5,280			
<b>制動系統 Brake</b>				
制動操作 Service	前碟後鼓式, 真空輔助油壓式制動, ABS防鎖制車系統 Front Disc, Rear Drum, Vacuum Servo Hydraulic, Anti-lock Brake System (ABS)			
停車手制 Parking	機械式傳動軸制動 Mechanical Parking Brake on Propeller Shaft			
輔助制動 Auxiliary	廢氣制動, 電子制動力分佈系統(EBD), 斜坡起動輔助系統(HSA), 防滑控制(ASR) Exhaust Brake, Electronic Braking Force Distribution (EBD), Hill-Start-Aid (HSA), Anti-Slip Regulator (ASR)		廢氣制動, 電子制動力分佈系統(EBD), 防滑控制(ASR) Exhaust Brake, Electronic Braking Force Distribution (EBD), Anti-Slip Regulator (ASR)	
<b>車陣 Frame</b>				
類型 Type	梯型車陣 Ladder Type			
陣闊(毫米) Width (mm)	850			
<b>輪胎及車輪 Tire &amp; Wheel</b>				
車胎 Tire	215/85R16 無內膽原子胎		215/85R16 Tubeless Radial Tire	
車輪 Wheel	16 x 6 (6 螺絲)		16 x 6 (6 Studs)	
<b>標準裝備 Standard Equipment</b>				
	原廠冷氣, 駕駛席SRS安全氣囊, AM/FM收音連CD機, 車門轉向輔助燈, 避震駕駛室, 電動車窗, 中央門鎖 Factory Built Air Conditioner, SRS Airbag on Driver Side, AM/FM CD Player, Door Mount Cornering Lamps, Cushioning Cab, Power Windows, Central Door Lock			

以上規格只供參考。如有更改, 恕不另行通告

062018

## NPR75HJW-VI / NPR75HJWE-VI

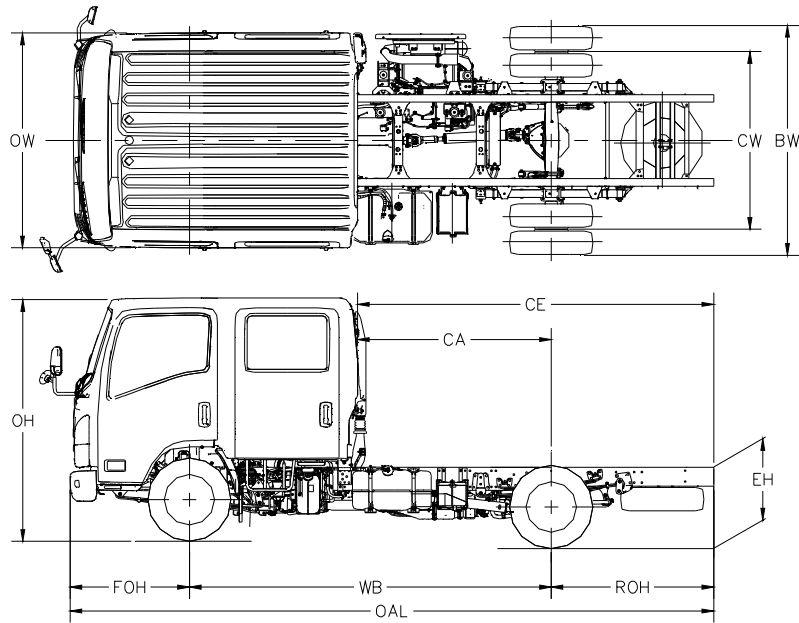

型號 (Model)	OAL	WB	FOH	ROH	CE	CA	OW	BW	CW	OH Approx	EH Approx	
NPR75HJW-VI/ NPR75HJWE-VI	5985	3365	1110	1510	3311	1801	1995	2135	1650	2245	835	毫米 (mm)
	235.6	132.5	43.7	59.4	130.4	70.9	78.5	84.1	65.0	88.4	32.9	寸 (in)

## NPR75KJW-VI / NPR75KJWE-VI

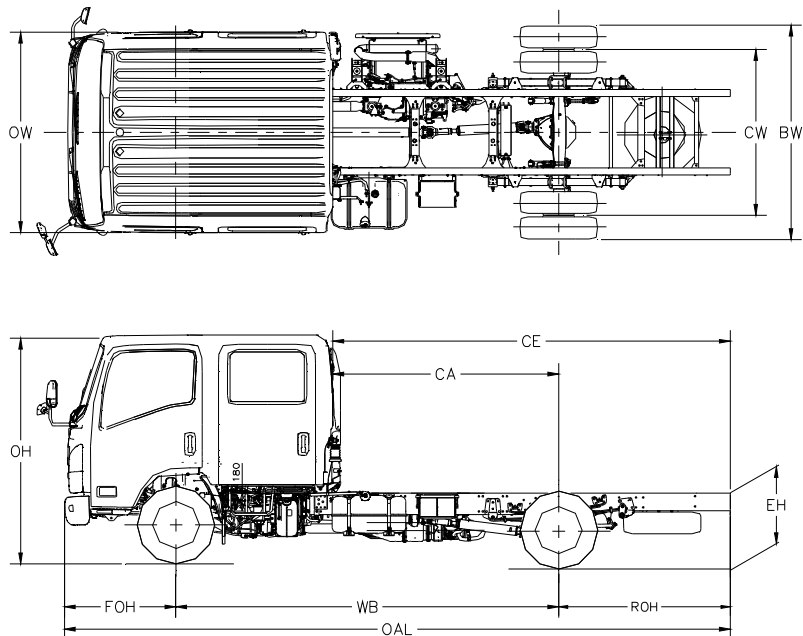

型號 (Model)	OAL	WB	FOH	ROH	CE	CA	OW	BW	CW	OH Approx	EH Approx	
NPR75KJW-VI/ NPR75KJWE-VI	6635	3815	1110	1710	3961	2251	1995	2135	1650	2245	835	毫米 (mm)
	261.2	150.2	43.7	67.3	155.9	88.6	78.5	84.1	65.0	88.4	32.9	寸 (in)

以上尺寸只供參考。如有更改，恕不另行通告。