

## 全新五十鈴環保6型 9噸車陣

型號 Model	NQR75 手波型號			NQR75 Smoother-Ex 電子自動波型號		
	NQR75K-VI-C	NQR75L-VI-C	NQR75KW-VI-C	NQR75KE-VI-C	NQR75LE-VI-C	NQR75KWE-VI-C
廢氣排放標準 Emission Standard	環保六型 Euro VI					
總重量(公斤) G.V.W. (kg)	9,000					
乘客量 (連司機) Seating Capacity	1 + 2 座位		1 + 5 座位	1 + 2 座位		1 + 5 座位
<b>車身尺寸 Dimensions</b>						
全長(毫米) Overall Length (mm)	6,635	7,515	6,635	6,635	7,515	6,635
全闊(毫米) Overall Width (mm)	2,115	2,115	2,115	2,115	2,115	2,115
全高(毫米) Overall Height (mm)	2,280	2,280	2,280	2,280	2,280	2,280
輪距(毫米) Wheelbase (mm)	3,815	4,175	3,815	3,815	4,175	3,815
<b>引擎 Engine</b>						
型號 Model	4HK1-E6C					
類別 Type	直列式四氣缸，16氣閥，可變活瓣渦輪增壓 (VGS Turbo) 連中置冷卻器，廢氣再循環裝置 (EGR)，電子控制高壓共軌噴注系統 (CRS)，柴油微粒過濾器+選擇性催化還原 (DPD+SCR) In-line, 4 Cylinders, 16 Valves, Variable Geometry System Turbocharger (VGS Turbo) with Intercooler Exhaust Gas Recirculation (EGR), Common Rail System (CRS), Diesel Particulate Diffuser (DPD) + Selective Catalytic Reduction (SCR)					
汽缸容積(毫升) Displacement (cc)	5,193					
最大馬力(匹/轉) Max. Output (PS/rpm)	190 / 2,600					
最大扭力(公斤-米/轉) Max. Torque (kgm/rpm)	52 / 1,600 ~ 2,600					
油缸容積(公升) Fuel Tank Capacity (litre)	100					
尿素缸容積(公升) Adblue Tank Capacity (litre)	16					
<b>波箱 Transmission</b>						
型號 Model	MZZ6U 6前1後 手動波箱 6 Forward 1 Reverse, Manual			MZZ6F 6前1後 "+/-"式電子自動波箱 6 Forward 1 Reverse, Smoother Ex "+/-" Automatic Shifting Device		
波段比 Gear Ratios	1 ~ 6波: 6.369 ~ 0.782			1 ~ 6波: 6.369 ~ 0.782		
最終傳動比 Final Gear Ratio	4.556			4.777		
<b>離合器 Clutch</b>						
類別 Type	單乾板式附避震彈簧，真空輔助控制 Dry Single Plate with Cushioning Spring, Vacuum Control			濕式多板離合器 Wet Type Multi Plate		
<b>轉向系統 Steering</b>						
類型 Type	走珠式動力輔助轉向系統 Recirculating Ball with Power Assisted					
<b>懸掛系統 Suspension</b>						
前懸掛 Front	半橢圓鋼合金多層葉片式彈簧，雙重液壓吸震筒 Semi-elliptical, Alloy Steel Leaf Spring, Double Acting Telescopic Shock Absorber					
後懸掛 Rear	半橢圓鋼合金多層葉片式彈簧，雙重液壓吸震筒 Semi-elliptical, Alloy Steel Leaf Spring, Double Acting Telescopic Shock Absorber					
前軸 Front Axle	倒置愛里奧工字架 Reverse Elliot "I" Beam					
廠方設計負重(公斤) Design Axle Loading (kg)	3,100					
運輸署批核負重(公斤) Allocated Weight (kg)	3,100					
後軸 Rear Axle	琵琶型全浮式 Banjo, Full Floating Type					
廠方設計負重(公斤) Design Axle Loading (kg)	6,600					
運輸署批核負重(公斤) Allocated Weight (kg)	6,400					
<b>制動系統 Brake</b>						
制動操作 Service	前後鼓式，液壓輔助油壓式制動 Front&Rear Drum, Hydraulic Servo Hydraulic					
停車手制 Parking	機械式傳動軸制動 Mechanical Parking Brake on Propeller Shaft					
輔助制動 Auxiliary	廢氣剎車，斜坡起動輔助系統(HSA) Exhaust Brake, Hill-Start-Aid (HSA)			廢氣剎車 Exhaust Brake		
<b>車陣 Frame</b>						
類型 Type	梯型車陣 Ladder Type					
陣闊(毫米) Width (mm)	850					
<b>輪胎及車輪 Tire&amp;Wheel</b>						
車胎 Tire	215/75R17.5 無內膽原子胎			215/75R17.5 Tubeless Radial Tire		
車輪 Wheel	17.5 x 6 (6 螺絲)			17.5 x 6 (6 Studs)		
<b>標準裝備 Standard Equipment</b>						
	原廠冷氣，駕駛席SRS安全氣囊 AM/FM收音連CD機，車門轉向輔助燈， 可揭式駕駛室(單排座型號)，避震駕駛室，電動車窗，中央門鎖 Factory Built Air Conditioner, SRS Airbag on Driver Side AM/FM CD Player, Door Mount Cornering Lamps Tilttable (Single Cab Only) and Cushioning Cab, Power Windows, Central Door Lock					

以上規格只供參考。如有更改，恕不另行通告。

062019

NQR75K-VI-C / NQR75KE-VI-C  
NQR75L-VI-C / NQR75LE-VI-C

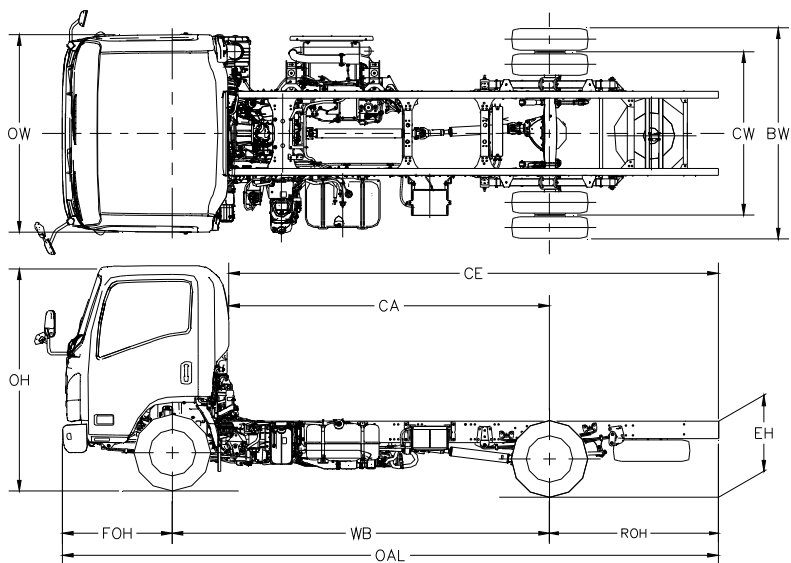

型號 (Model)	OAL	WB	FOH	ROH	CE	CA	OW	BW	CW	OH Approx	EH Approx	
NQR75K-VI-C / NQR75KE-VI-C	6635	3815	1110	1710	4952	3242	1995	2115	1650	2280	835	毫米 (mm)
	261.2	150.2	43.7	67.3	195.0	127.6	78.5	83.3	65.0	89.8	32.9	寸 (in)
NQR75L-VI-C / NQR75LE-VI-C	7515	4175	1110	2230	5832	3602	1995	2115	1650	2280	835	毫米 (mm)
	295.9	164.4	43.7	87.8	229.6	141.8	78.5	83.3	65.0	89.8	32.9	寸 (in)

NQR75KW-VI-C / NQR75KWE-VI-C

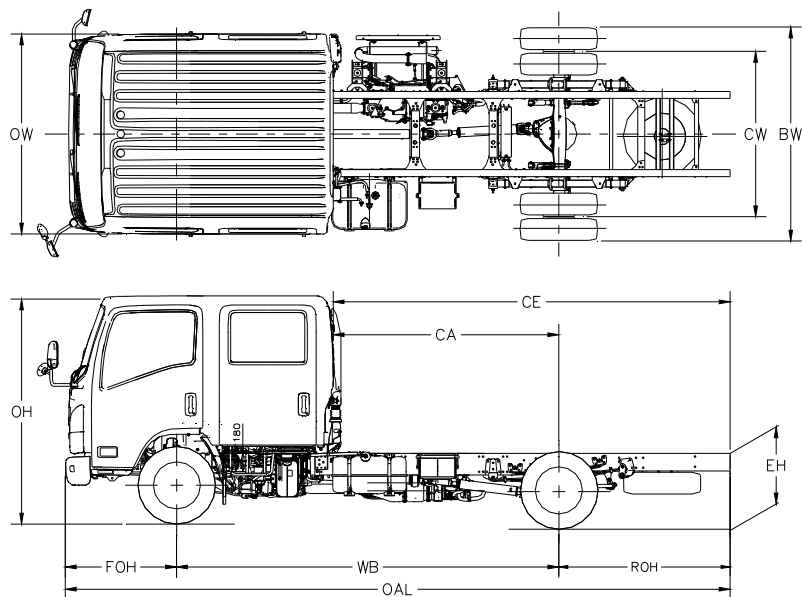

型號 (Model)	OAL	WB	FOH	ROH	CE	CA	OW	BW	CW	OH Approx	EH Approx	
NQR75KW-VI-C / NQR75KWE-VI-C	6635	3815	1110	1710	3961	2251	1995	2115	1650	2280	835	毫米 (mm)
	261.2	150.2	43.7	67.3	155.9	88.6	78.5	83.3	65.0	89.8	32.9	寸 (in)

以上尺寸只供參考。如有更改，恕不另行通告。