

全新五十鈴環保6型 11噸車陣

型號 Model	FRR90 手波型號		FRR90 Smoother-F 電子自動波型號	
	FRR90K-VI-C	FRR90M-VI-C	FRR90KF-VI-C	FRR90MF-VI-C
廢氣排放標準 Emission Standard	環保六型 Euro VI			
總重量(公斤) G.V.W. (kg)	11,000			
乘客量(連司機) Seating Capacity	1 + 2 座位 (DAY CAB)			
車身尺寸 Dimensions				
全長(毫米) Overall Length (mm)	6,975	7,875	6,975	7,875
全闊(毫米) Overall Width (mm)	2,200	2,200	2,200	2,200
全高(毫米) Overall Height (mm)	2,530	2,530	2,530	2,530
輪距(毫米) Wheelbase (mm)	4,060	4,660	4,060	4,660
引擎 Engine				
型號 Model	4HK1-E6S-C			
類別 Type	直列式四氣缸，16氣閥，可變活瓣渦輪增壓 (VGS Turbo)連中置冷卻器， 廢氣再循環裝置 (EGR)，電子控制高壓共軌噴注系統 (CRS)， 柴油微粒過濾器+選擇性催化還原 (DPD+SCR) In-line, 4 Cylinders, 16 Valves, Variable Geometry System Turbocharger (VGS Turbo) with Intercooler Exhaust Gas Recirculation (EGR), Common Rail System (CRS), Diesel Particulate Diffuser (DPD) + Selective Catalytic Reduction (SCR)			
汽缸容積(毫升) Displacement (cc)	5,193			
最大馬力(匹/轉) Max. Output (PS/rpm)	209 / 2,400			
最大扭力(公斤-米/轉) Max. Torque (kgm/rpm)	72 / 1,600			
油缸容積(公升) Fuel Tank Capacity (litre)	200			
尿素缸容積(公升) Adblue Tank Capacity (litre)	16			
波箱 Transmission				
型號 Model	MZW6P 6前1後 手動波箱 6 Forward 1 Reverse, Manual		MZW6P 6前1後 6前1後 "+/-"式電子自動波箱 6 Forward 1 Reverse, Smoother F "+/-" Automatic Shifting Device	
波段比 Gear Ratios	1 ~ 6波 : 6.615 ~ 0.722			
最終傳動比 Final Gear Ratio	4.875			
離合器 Clutch				
類別 Type	單乾板式附避震彈簧，空氣輔助液壓控制 Dry Single Plate with Cushioning Spring, Hydraulic Control with Air Assisted		濕式多板離合器 Wet Type Multi Plate	
轉向系統 Steering				
類型 Type	走珠式動力輔助轉向系統 Recirculating Ball with Power Assisted			
懸掛系統 Suspension				
前懸掛 Front	半橢圓鋼合金多層葉片式彈簧，雙重液壓吸震筒，防滾桿 Semi-elliptical, Alloy Steel Leaf Spring, Double Acting Telescopic Shock Absorber, Anti-roll Bar			
後懸掛 Rear	半橢圓鋼合金多層葉片式彈簧 Semi-elliptical, Alloy Steel Leaf Spring			
前軸 Front Axle	倒置愛里奧工字架 Reverse Elliot "I" Beam			
廠方設計負重(公斤) Design Axle Loading (kg)	3,600			
運輸署批核負重(公斤) Allocated Weight (kg)	3,600			
後軸 Rear Axle	琵琶型全浮式 Banjo, Full Floating Type			
廠方設計負重(公斤) Design Axle Loading (kg)	7,700			
運輸署批核負重(公斤) Allocated Weight (kg)	7,600			
制動系統 Brake				
制動操作 Service	前後鼓刹，氣動輔助液壓式制動，虛位自動調節器，ABS防鎖刹車系統 Front&Rear Drum, Air Over Hydraulic, Brake Auto Adjuster, Anti-lock Brake System (ABS)			
停車手制 Parking	後輪彈簧制動器 Spring Brake Actuators Acting on Rear Wheels			
輔助制動 Auxiliary	廢氣刹車，斜坡起動輔助系統(HSA) Exhaust Brake, Hill-Start-Aid (HSA)			
車陣 Frame				
類型 Type	梯型車陣 Ladder Type			
陣闊(毫米) Width (mm)	840			
輪胎及車輪 Tire&Wheel				
車胎 Tire	235/75R17.5 無內膽原子胎		235/75R17.5 Tubeless Radial Tire	
車輪 Wheel	17.5 x 6.75 (6 螺絲)		17.5 x 6.75 (6 Studs)	
標準裝備 Standard Equipment				
	原廠冷氣，駕駛席SRS安全氣囊 AM/FM收音連CD機，車門轉向輔助燈 可揭式駕駛室，避震駕駛室，電動車窗，中央門鎖 電動調較角度及電動摺鏡臂(乘客座)，發熱線後鏡 Factory Built Air Conditioner, SRS Airbag on Driver Side AM/FM CD Player, Door Mount Cornering Lamps Tilttable and Cushioning Cab, Power Windows, Central Door Lock Electronic Adjustable and Retractable Side Mirror (Passenger Side), Heated Side Mirrors			

FRR90K-VI-C / FRR90KF-VI-C
FRR90M-VI-C / FRR90MF-VI-C

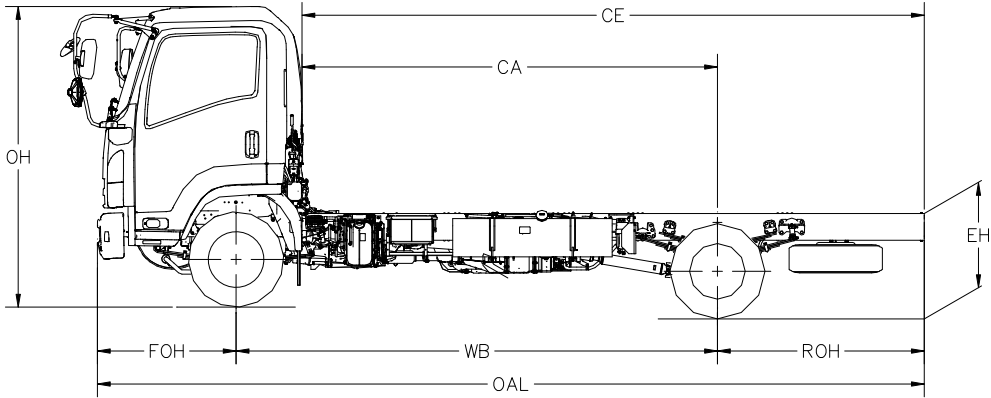
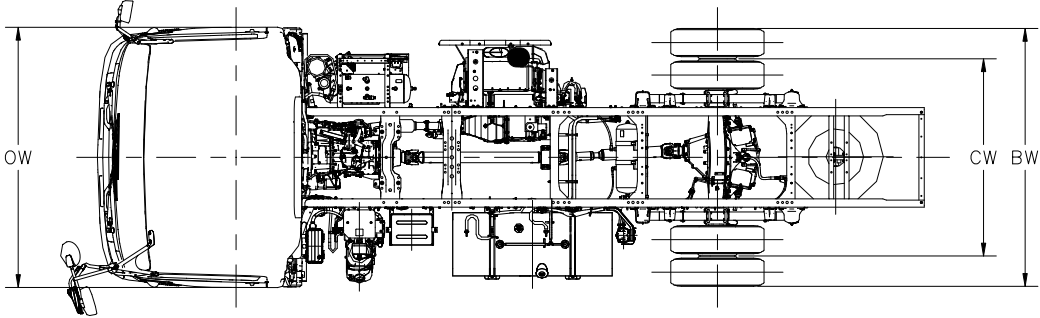

型號 (Model)	OAL	WB	FOH	ROH	CE	CA	OW	BW	CW	OH Approx	EH Approx	
FRR90K-VI-C/ FRR90KF-VI-C	6975	4060	1170	1745	5249	3504	2200	2170	1660	2530	940	毫米 (mm)
	275	160	46	69	207	138	87	85	65	100	37	寸 (in)
FRR90M-VI-C/ FRR90MF-VI-C	7875	4660	1170	2045	6149	4104	2200	2170	1660	2530	940	毫米 (mm)
	310	183	46	81	242	162	87	85	65	100	37	寸 (in)

以上尺寸只供參考。如有更改，恕不另行通告。