

全新五十鈴環保6型 5.2噸車陣

| 型號 Model | NMR85 手波型號 | | NMR85 Smoother-Ex 電子自動波型號 | |
|--|---|-------------|---|--------------|
| | NMR85F-VI-C | NMR85H-VI-C | NMR85FE-VI-C | NMR85HE-VI-C |
| 廢氣排放標準 Emission Standard | 環保六型 Euro VI | | | |
| 總重量(公斤) G.V.W. (kg) | 5,200 | | | |
| 乘客量(連司機) Seating Capacity | 1 + 2 座位 | | | |
| 車身尺寸 Dimensions | | | | |
| 全長(毫米) Overall Length (mm) | 5,250 | 6,020 | 5,250 | 6,020 |
| 全闊(毫米) Overall Width (mm) | 1,865 | 1,865 | 1,865 | 1,865 |
| 全高(毫米) Overall Height (mm) | 2,160 | 2,160 | 2,160 | 2,160 |
| 輪距(毫米) Wheelbase (mm) | 2,750 | 3,350 | 2,750 | 3,350 |
| 引擎 Engine | | | | |
| 型號 Model | 4JJ1E6N-C | | | |
| 類別 Type | 直列式四氣缸，16氣閥，可變活瓣渦輪增壓 (VGS Turbo)連中置冷卻器， 廢氣再循環裝置 (EGR)，電子控制高壓共軌噴注系統 (CRS)， 柴油微粒過濾器+選擇性催化還原 (DPD+SCR) In-line, 4 Cylinders, 16 Valves, Variable Geometry System Turbocharger (VGS Turbo) with Intercooler Exhaust Gas Recirculation (EGR), Common Rail System (CRS), Diesel Particulate Diffuser (DPD) + Selective Catalytic Reduction (SCR) | | | |
| 汽缸容積(毫升) Displacement (cc) | 2,999 | | | |
| 最大馬力(匹/轉) Max. Output (PS/rpm) | 150 / 2,800 | | | |
| 最大扭力(公斤-米/轉) Max. Torque (kgm/rpm) | 38.2 / 1,600 - 2,800 | | | |
| 油缸容積(公升) Fuel Tank Capacity (litre) | 75 | 100 | 75 | 100 |
| 尿素缸容積(公升) Adblue Tank Capacity (litre) | 16 | | | |
| 波箱 Transmission | | | | |
| 型號 Model | MYY5T 5前1後 手動波箱 5 Forward 1 Reverse, Manual | | MYY6S 6前1後 "+/-"式電子自動波箱 6 Forward 1 Reverse, Smoother Ex "+/-" Automatic Shifting Device | |
| 波段比 Gear Ratios | 1 ~ 5波 : 5.315 ~ 0.721 | | 1 ~ 6 波 : 5.979 ~ 0.759 | |
| 最終傳動比 Final Gear Ratio | 5.125 | | 4.3 | |
| 離合器 Clutch | | | | |
| 類別 Type | 單乾板式附避震彈簧，真空液壓輔助控制 Dry Single Plate with Cushioning Spring, Vacuum Control | | 濕式多板離合器 Wet Type Multi Plate | |
| 轉向系統 Steering | | | | |
| 類型 Type | 走珠式動力輔助轉向系統 Recirculating Ball with Power Assisted | | | |
| 懸掛系統 Suspension | | | | |
| 前懸掛 Front | 龍船葉片式彈簧，雙重液壓吸震筒 Taper Leaf Spring, Double Acting Telescopic Shock Absorber | | | |
| 後懸掛 Rear | 半橢圓鋼合金多層葉片式彈簧，雙重液壓吸震筒，防滾桿 Semi-elliptical, Alloy Steel Leaf Spring, Double Acting Telescopic Shock Absorber, Anti-roll Bar | | | |
| 前軸 Front Axle | 倒置愛里奧工字架 Reverse Elliot "I" Beam | | | |
| 廠方設計負重(公斤) Design Axle Loading (kg) | 2,900 | | | |
| 運輸署批核負重(公斤) Allocated Weight (kg) | 2,360 | | | |
| 後軸 Rear Axle | 琵琶型全浮式 Banjo, Full Floating Type | | | |
| 廠方設計負重(公斤) Design Axle Loading (kg) | 5,000 | | | |
| 運輸署批核負重(公斤) Allocated Weight (kg) | 4,480 | | | |
| 制動系統 Brake | | | | |
| 制動操作 Service | 前碟後鼓式，真空輔助油壓式制動，ABS防鎖制車系統 Front Disc, Rear Drum, Vacuum Servo Hydraulic, Anti-lock Brake System (ABS) | | | |
| 停車手制 Parking | 機械式傳動輸出軸制動 Mechanical Parking Brake on Propeller Shaft | | | |
| 輔助制動 Auxiliary | 廢氣制車，電子制動力分佈系統(EBD)， 斜坡起動輔助系統(HSA)，防滑控制(ASR) Exhaust Brake, Electronic Braking Force Distribution (EBD), Hill-Start-Aid (HSA), Anti-Slip Regulator (ASR) | | 廢氣制車，電子制動力分佈系統(EBD)， 防滑控制(ASR) Exhaust Brake, Electronic Braking Force Distribution (EBD), Anti-Slip Regulator (ASR) | |
| 車陣 Frame | | | | |
| 類型 Type | 梯型車陣 Ladder Type | | | |
| 陣闊(毫米) Width (mm) | 700 | | | |
| 輪胎及車輪 Tire & Wheel | | | | |
| 車胎 Tire | 195/85R16 無內膽原子胎 | | 195/85R16 Tubeless Radial Tire | |
| 車輪 Wheel | 16 x 5.5 (5 螺絲) | | 16 x 5.5 (5 Studs) | |
| 標準裝備 Standard Equipment | | | | |
| | 原廠冷氣，駕駛席SRS安全氣囊 AM/FM收音連CD機，車門轉向輔助燈， 可揭式駕駛室，避震駕駛室，電動車窗，中央門鎖 Factory Built Air Conditioner, SRS Airbag on Driver Side AM/FM CD Player, Door Mount Cornering Lamps Tilttable and Cushioning Cab, Power Windows, Central Door Lock | | | |

以上規格只供參考。如有更改，恕不另行通告。

092020

NMR85F-VI-C / NMR85FE-VI-C

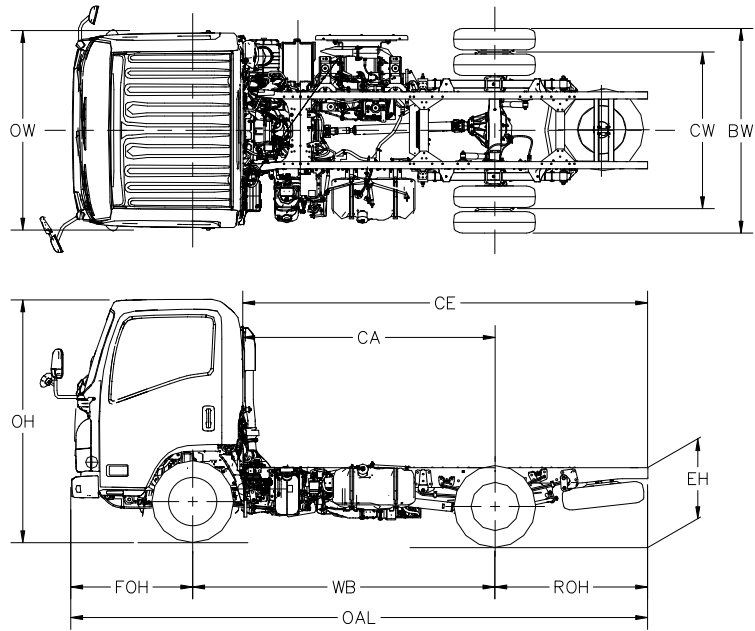

| 型號 (Model) | OAL | WB | FOH | ROH | CE | CA | OW | BW | CW | OH Approx | EH Approx | |
|------------------------------|-------|-------|------|------|-------|------|------|------|------|--------------|--------------|---------|
| NMR85F-VI-C/ NMR85FE-VI-C | 5250 | 2750 | 1110 | 1390 | 3687 | 2297 | 1815 | 1865 | 1425 | 2160 | 727 | 毫米 (mm) |
| | 206.7 | 108.3 | 43.7 | 54.7 | 145.2 | 90.4 | 71.5 | 73.4 | 56.1 | 85.0 | 28.6 | 寸 (in) |

NMR85H-VI-C / NMR85HE-VI-C

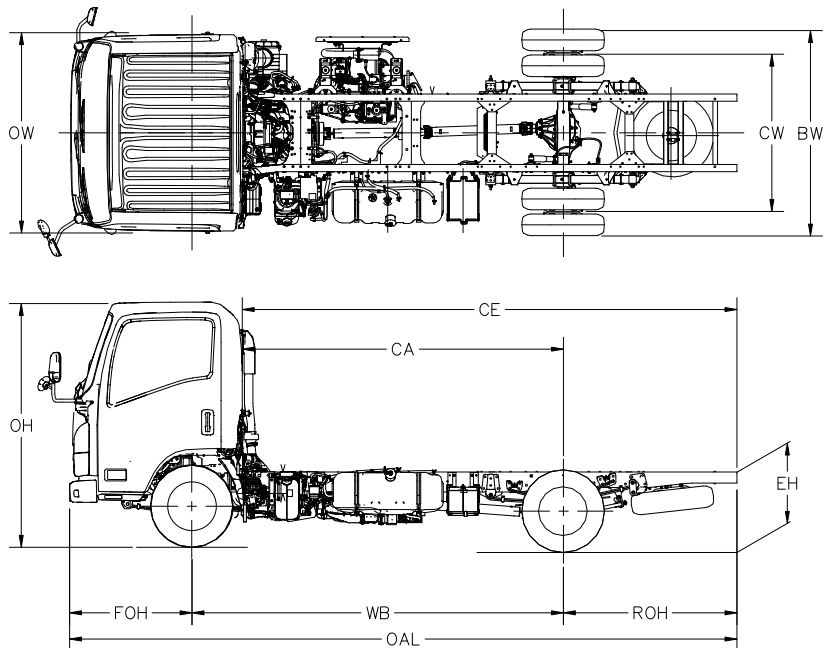

| 型號 (Model) | OAL | WB | FOH | ROH | CE | CA | OW | BW | CW | OH Approx | EH Approx | |
|------------------------------|-------|-------|------|------|-------|-------|------|------|------|--------------|--------------|---------|
| NMR85H-VI-C/ NMR85HE-VI-C | 6020 | 3350 | 1110 | 1560 | 4462 | 2897 | 1815 | 1865 | 1425 | 2160 | 765 | 毫米 (mm) |
| | 237.0 | 131.9 | 43.7 | 61.4 | 175.7 | 114.1 | 71.5 | 73.4 | 56.1 | 85.0 | 30.1 | 寸 (in) |

以上尺寸只供參考。如有更改，恕不另行通告。