

全新五十鈴環保6型 7.5噸車陣

| 型號 Model | NPR75 手波型號 | | | NPR75 Smoother-Ex 電子自動波型號 | | |
|--|--|--------------|--------------|--|---------------|---------------|
| | NPR75FL-VI-C | NPR75HL-VI-C | NPR75KL-VI-C | NPR75FLE-VI-C | NPR75HLE-VI-C | NPR75KLE-VI-C |
| 廢氣排放標準 Emission Standard | 環保六型 Euro VI | | | | | |
| 總重量(公斤) G.V.W. (kg) | 7,500 | | | | | |
| 乘客量(連司機) Seating Capacity | 1 + 2 座位 | | | | | |
| 車身尺寸 Dimensions | | | | | | |
| 全長(毫米) Overall Length (mm) | 5,385 | 5,985 | 6,635 | 5,385 | 5,985 | 6,635 |
| 全闊(毫米) Overall Width (mm) | 2,115 | 2,115 | 2,115 | 2,115 | 2,115 | 2,115 |
| 全高(毫米) Overall Height (mm) | 2,280 | 2,280 | 2,280 | 2,280 | 2,280 | 2,280 |
| 輪距(毫米) Wheelbase (mm) | 2,765 | 3,365 | 3,815 | 2,765 | 3,365 | 3,815 |
| 引擎 Engine | | | | | | |
| 型號 Model | 4HK1E6C-C | | | | | |
| 類別 Type | 直列式四氣缸，16氣閥，可變活瓣渦輪增壓 (VGS Turbo) 連中置冷卻器，廢氣再循環裝置 (EGR)，電子控制高壓共軌噴注系統 (CRS)，柴油微粒過濾器+選擇性催化還原 (DPD+SCR) In-line, 4 Cylinders, 16 Valves, Variable Geometry System Turbocharger (VGS Turbo) with Intercooler Exhaust Gas Recirculation (EGR), Common Rail System (CRS), Diesel Particulate Diffuser (DPD) + Selective Catalytic Reduction (SCR) | | | | | |
| 汽缸容積(毫升) Displacement (cc) | 5,193 | | | | | |
| 最大馬力(匹轉) Max. Output (PS/rpm) | 190 / 2,600 | | | | | |
| 最大扭力(公斤-米轉) Max. Torque (kgm/rpm) | 52 / 1,600 ~ 2,600 | | | | | |
| 油缸容積(公升) Fuel Tank Capacity (litre) | 100 | | | | | |
| 尿素缸容積(公升) Adblue Tank Capacity (litre) | 16 | | | | | |
| 波箱 Transmission | | | | | | |
| 型號 Model | MZZ6F 6前1後 手動波箱 6 Forward 1 Reverse, Manual | | | MZZ6F 6前1後 "+/-"式電子自動波箱 6 Forward 1 Reverse, Smoother Ex "+/-" Automatic Shifting Device | | |
| 波段比 Gear Ratios | 1 ~ 6波 : 6.369 ~ 0.782 | | | | | |
| 最終傳動比 Final Gear Ratio | 4.1 | | | | | |
| 離合器 Clutch | | | | | | |
| 類別 Type | 單乾板式附避震彈簧，真空輔助控制 Dry Single Plate with Cushioning Spring, Vacuum Control | | | 濕式多板離合器 Wet Type Multi Plate | | |
| 轉向系統 Steering | | | | | | |
| 類型 Type | 走珠式動力輔助轉向系統 Recirculating Ball with Power Assisted | | | | | |
| 懸掛系統 Suspension | | | | | | |
| 前懸掛 Front | 半橢圓鋼合金多層葉片式彈簧，雙重液壓吸震筒，防滾桿(只限短陣型號) Semi-elliptical, Alloy Steel Leaf Spring, Double Acting Telescopic Shock Absorber, Anti-roll Bar (Short WB only) | | | | | |
| 後懸掛 Rear | 半橢圓鋼合金多層葉片式彈簧，雙重液壓吸震筒，防滾桿 Semi-elliptical, Alloy Steel Leaf Spring, Double Acting Telescopic Shock Absorber, Anti-roll Bar | | | | | |
| 前軸 Front Axle | 倒置愛里奧工字架 Reverse Elliot "I" Beam | | | | | |
| 廠方設計負重(公斤) Design Axle Loading (kg) | 3,100 | | | | | |
| 運輸署批核負重(公斤) Allocated Weight (kg) | 3,100 | | | | | |
| 後軸 Rear Axle | 琵琶型全浮式 Banjo, Full Floating Type | | | | | |
| 廠方設計負重(公斤) Design Axle Loading (kg) | 6,600 | | | | | |
| 運輸署批核負重(公斤) Allocated Weight (kg) | 6,400 | | | | | |
| 制動系統 Brake | | | | | | |
| 制動操作 Service | 前碟後鼓式，液壓輔助油壓式制動，ABS防鎖剎車系統 Front Disc, Rear Drum, Hydraulic Servo Hydraulic, Anti-lock Brake System (ABS) | | | | | |
| 停車手制 Parking | 機械式傳動軸制動 Mechanical Parking Brake on Propeller Shaft | | | | | |
| 輔助制動 Auxiliary | 廢氣剎車，電子制動力分佈系統(EBD)，斜坡起動輔助系統(HSA)，防滑控制(ASR) Exhaust Brake, Electronic Braking Force Distribution (EBD), Hill-Start-Aid (HSA), Anti-Slip Regulator (ASR) | | | 廢氣剎車，電子制動力分佈系統(EBD)，防滑控制(ASR) Exhaust Brake, Electronic Braking Force Distribution (EBD), Anti-Slip Regulator (ASR) | | |
| 車陣 Frame | | | | | | |
| 類型 Type | 梯型車陣 Ladder Type | | | | | |
| 陣闊(毫米) Width (mm) | 850 | | | | | |
| 輪胎及車輪 Tire & Wheel | | | | | | |
| 車胎 Tire | 215/75R17.5 無內膽原子胎 | | | 215/75R17.5 Tubeless Radial Tire | | |
| 車輪 Wheel | 17.5 x 6 (6 螺絲) | | | 17.5 x 6 (6 Studs) | | |
| 標準裝備 Standard Equipment | | | | | | |
| | 原廠冷氣，駕駛席SRS安全氣囊 AM/FM收音連CD機，車門轉向輔助燈， 可揭式駕駛室，避震駕駛室，電動車窗，中央門鎖 Factory Built Air Conditioner, SRS Airbag on Driver Side AM/FM CD Player, Door Mount Cornering Lamps Tilttable and Cushioning Cab, Power Windows, Central Door Lock | | | | | |

以上規格只供參考。如有更改，恕不另行通告。

092020

NPR75FL-VI-C / NPR75FLE-VI-C

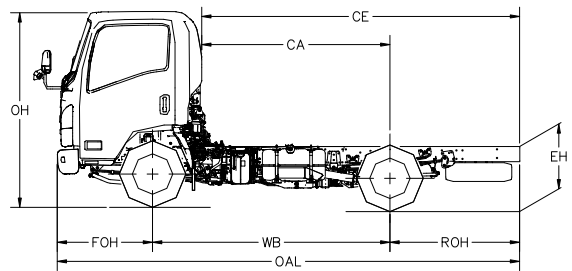
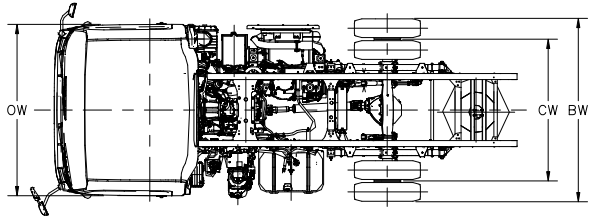

| 型號 (Model) | OAL | WB | FOH | ROH | CE | CA | OW | BW | CW | OH | EH | |
|--------------------------------|-------|-------|------|------|-------|------|------|------|------|----------------|---------------|---------|
| NPR75FL-VI-C/ NPR75FLE-VI-C | 5385 | 2765 | 1110 | 1510 | 3702 | 2192 | 1995 | 2115 | 1650 | Approx 2280 | Approx 835 | 毫米 (mm) |
| | 212.0 | 108.9 | 43.7 | 59.4 | 145.7 | 86.3 | 78.5 | 83.3 | 65.0 | 89.8 | 32.9 | 寸 (in) |

NPR75HL-VI-C / NPR75HLE-VI-C

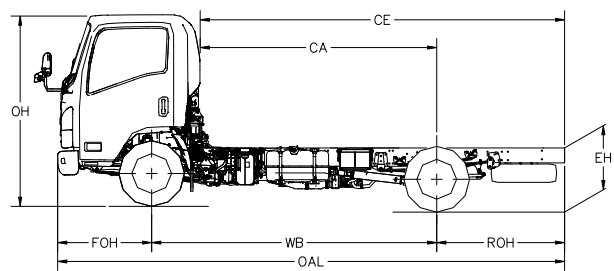
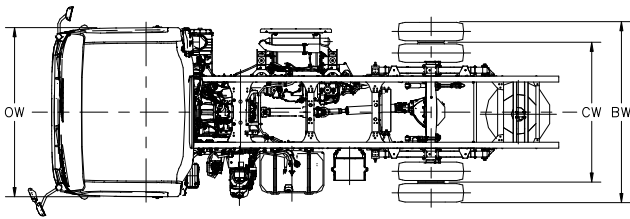

| 型號 (Model) | OAL | WB | FOH | ROH | CE | CA | OW | BW | CW | OH | EH | |
|--------------------------------|-------|-------|------|------|-------|-------|------|------|------|----------------|---------------|---------|
| NPR75HL-VI-C/ NPR75HLE-VI-C | 5985 | 3365 | 1110 | 1510 | 4302 | 2792 | 1995 | 2115 | 1650 | Approx 2280 | Approx 835 | 毫米 (mm) |
| | 235.6 | 132.5 | 43.7 | 59.4 | 169.4 | 109.9 | 78.5 | 83.3 | 65.0 | 89.8 | 32.9 | 寸 (in) |

NPR75KL-VI-C / NPR75KLE-VI-C

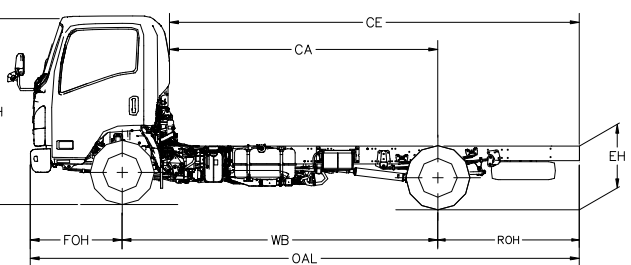
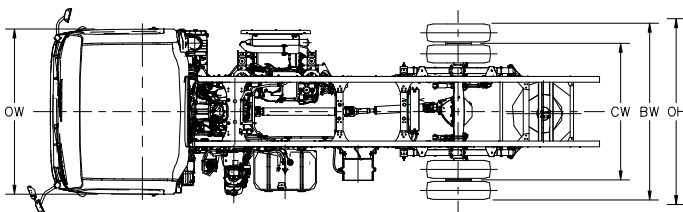

| 型號 (Model) | OAL | WB | FOH | ROH | CE | CA | OW | BW | CW | OH | EH | |
|--------------------------------|-------|-------|------|------|-------|-------|------|------|------|----------------|---------------|---------|
| NPR75KL-VI-C/ NPR75KLE-VI-C | 6635 | 3815 | 1110 | 1710 | 4952 | 3242 | 1995 | 2115 | 1650 | Approx 2280 | Approx 835 | 毫米 (mm) |
| | 261.2 | 150.2 | 43.7 | 67.3 | 195.0 | 127.6 | 78.5 | 83.3 | 65.0 | 89.8 | 32.9 | 寸 (in) |

以上尺寸只供參考。如有更改，恕不另行通告。

全新五十鈴環保6型 7.5噸車陣(雙排座)

| | NPR75 手波型號 NPR75KLW-VI-C | NPR75 Smoother-Ex 電子自動波型號 NPR75KLWE-VI-C |
|--|---|---|
| 型號 Model | 環保六型 Euro VI | |
| 廢氣排放標準 Emission Standard | 7,500 | |
| 總重量(公斤) G.V.W. (kg) | 1 + 5 座位 | |
| 乘客量(連司機) Seating Capacity | | |
| 車身尺寸 Dimensions | | |
| 全長(毫米) Overall Length (mm) | 6,635 | 6,635 |
| 全闊(毫米) Overall Width (mm) | 2,115 | 2,115 |
| 全高(毫米) Overall Height (mm) | 2,280 | 2,280 |
| 輪距(毫米) Wheelbase (mm) | 3,815 | 3,815 |
| 引擎 Engine | | |
| 型號 Model | 4HK1E6C-C | |
| 類別 Type | 直列式四氣缸，16氣閥，可變活瓣渦輪增壓 (VGS Turbo)連中置冷卻器， 廢氣再循環裝置 (EGR)，電子控制高壓共軌噴注系統 (CRS)， 柴油微粒過濾器+選擇性催化還原 (DPD+SCR) In-line, 4 Cylinders, 16 Valves, Variable Geometry System Turbocharger (VGS Turbo) with Intercooler Exhaust Gas Recirculation (EGR), Common Rail System (CRS), Diesel Particulate Diffuser (DPD) + Selective Catalytic Reduction (SCR) | |
| 汽缸容積(毫升) Displacement (cc) | 5,193 | |
| 最大馬力(匹/轉) Max. Output (PS/rpm) | 190 / 2,600 | |
| 最大扭力(公斤-米/轉) Max. Torque (kgm/rpm) | 52 / 1,600 ~ 2,600 | |
| 油缸容積(公升) Fuel Tank Capacity (litre) | 100 | |
| 尿素缸容積(公升) Adblue Tank Capacity (litre) | 16 | |
| 波箱 Transmission | | |
| 型號 Model | MZZ6F 6前1後 手動波箱 6 Forward 1 Reverse, Manual | MZZ6F 6前1後 "+/-"式電子自動波箱 6 Forward 1 Reverse, Smoother Ex "+/-" Automatic Shifting Device |
| 波段比 Gear Ratios | 1 ~ 6波：6.369 ~ 0.782 | |
| 最終傳動比 Final Gear Ratio | 4.1 | |
| 離合器 Clutch | | |
| 類別 Type | 單乾板式附避震彈簧，真空輔助控制 Dry Single Plate with Cushioning Spring, Vacuum Control | 濕式多板離合器 Wet Type Multi Plate |
| 轉向系統 Steering | | |
| 類型 Type | 走珠式動力輔助轉向系統 Recirculating Ball with Power Assisted | |
| 懸掛系統 Suspension | | |
| 前懸掛 Front | 半橢圓鋼合金多層葉片式彈簧，雙重液壓吸震筒 Semi-elliptical, Alloy Steel Leaf Spring, Double Acting Telescopic Shock Absorber | |
| 後懸掛 Rear | 半橢圓鋼合金多層葉片式彈簧，雙重液壓吸震筒 Semi-elliptical, Alloy Steel Leaf Spring, Double Acting Telescopic Shock Absorber | |
| 前軸 Front Axle | 倒置愛里奧工字架 Reverse Elliot "I" Beam | |
| 廠方設計負重(公斤) Design Axle Loading (kg) | 3,100 | |
| 運輸署批核負重(公斤) Allocated Weight (kg) | 3,100 | |
| 後軸 Rear Axle | 琵琶型全浮式 Banjo, Full Floating Type | |
| 廠方設計負重(公斤) Design Axle Loading (kg) | 6,600 | |
| 運輸署批核負重(公斤) Allocated Weight (kg) | 6,400 | |
| 制動系統 Brake | | |
| 制動操作 Service | 前碟後鼓式，液壓輔助油壓式制動，ABS防鎖剎車系統 Front Disc, Rear Drum, Hydraulic Servo Hydraulic, Anti-lock Brake System (ABS) | |
| 停車手制 Parking | 機械式傳動軸制動 Mechanical Parking Brake on Propeller Shaft | |
| 輔助制動 Auxiliary | 廢氣剎車，電子制動力分佈系統(EBD)， 斜坡起動輔助系統(HSA)，防滑控制(ASR) Exhaust Brake, Electronic Braking Force Distribution (EBD), Hill-Start-Aid (HSA), Anti-Slip Regulator (ASR) | 廢氣剎車，電子制動力分佈系統(EBD)， 防滑控制(ASR) Exhaust Brake, Electronic Braking Force Distribution (EBD), Anti-Slip Regulator (ASR) |
| 車陣 Frame | | |
| 類型 Type | 梯型車陣 Ladder Type | |
| 陣闊(毫米) Width (mm) | 850 | |
| 輪胎及車輪 Tire&Wheel | | |
| 車胎 Tire | 215/75R17.5 無內膽原子胎 | 215/75R17.5 Tubeless Radial Tire |
| 車輪 Wheel | 17.5 x 6 (6 螺絲) | 17.5 x 6 (6 Studs) |
| 標準裝備 Standard Equipment | | |
| | 原廠冷氣，駕駛席SRS安全氣囊 AM/FM收音連CD機，車門轉向輔助燈， 避震駕駛室，電動車窗，中央門鎖 Factory Built Air Conditioner, SRS Airbag on Driver Side AM/FM CD Player, Door Mount Cornering Lamps Cushioning Cab, Power Windows, Central Door Lock | |

以上規格只供參考。如有更改，恕不另行通告

092020

NPR75KLW-VI-C / NPR75KLWE-VI-C

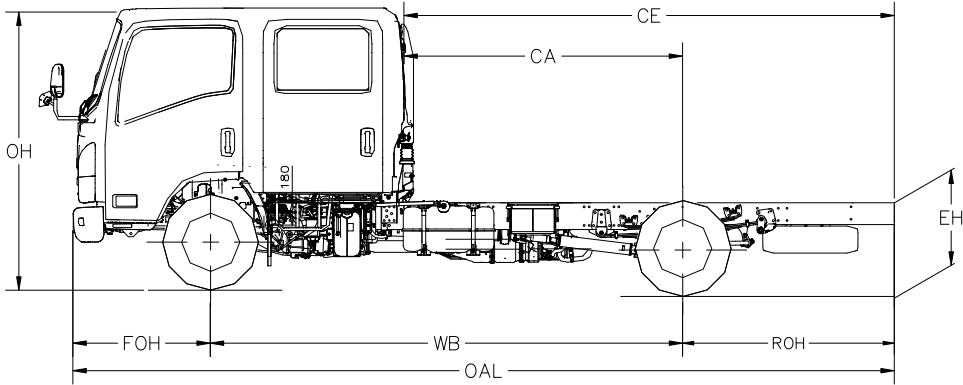
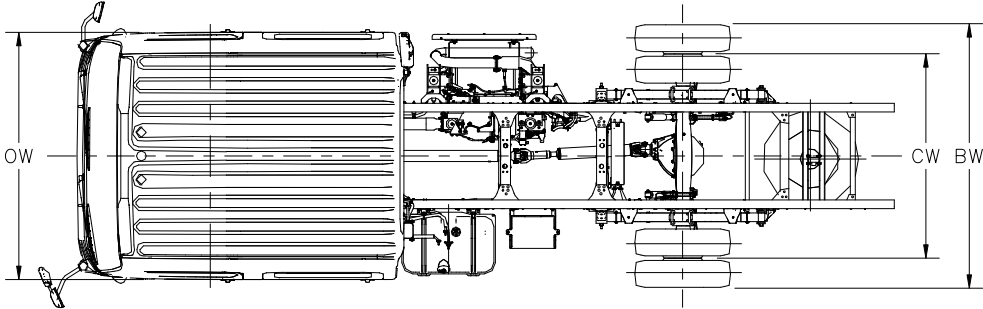

| 型號 (Mdoel) | OAL | WB | FOH | ROH | CE | CA | OW | BW | CW | OH Approx | EH Approx | |
|---------------------------------|-------|-------|------|------|-------|------|------|------|------|--------------|--------------|---------|
| NPR75KLW-VI-C/ NPR75KLWE-VI- | 6635 | 3815 | 1110 | 1710 | 3961 | 2251 | 1995 | 2115 | 1650 | 2245 | 835 | 毫米 (mm) |
| | 261.2 | 150.2 | 43.7 | 67.3 | 155.9 | 88.6 | 78.5 | 83.3 | 65.0 | 88.4 | 32.9 | 寸 (in) |

以上尺寸只供參考。如有更改，恕不另行通告。